

Glodanje industrijskim robotom

Mudri, Marko

Undergraduate thesis / Završni rad

2021

Degree Grantor / Ustanova koja je dodijelila akademski / stručni stupanj: **Bjelovar University of Applied Sciences / Veleučilište u Bjelovaru**

Permanent link / Trajna poveznica: <https://um.nsk.hr/um:nbn:hr:144:242560>

Rights / Prava: [In copyright](#)/[Zaštićeno autorskim pravom.](#)

Download date / Datum preuzimanja: **2025-03-13**



Repository / Repozitorij:

[Digital Repository of Bjelovar University of Applied Sciences](#)



VELEUČILIŠTE U BJELOVARU
PREDDIPLOMSKI STRUČNI STUDIJ MEHATRONIKA

GLODANJE INDUSTRIJSKIM ROBOTOM

Završni rad br. 07/MEH/2021

Marko Mudri

Bjelovar, listopad 2021.



Veleučilište u Bjelovaru
Trg E. Kvaternika 4, Bjelovar

1. DEFINIRANJE TEME ZAVRŠNOG RADA I POVJERENSTVA

Kandidat: **Mudri Marko**

Datum: 27.09.2021.

Matični broj: 001759

Kolegij: **PRIMIJEJENA ROBOTIKA**

JMBAG: 0314017377

Naslov rada (tema): **Glodanje industrijskim robotom**

Područje: **Tehničke znanosti**

Polje: **Strojarstvo**

Grana: **Proizvodno strojarstvo**

Mentor: **Tomislav Pavlic, mag.ing.mech.**

zvanje: **viši predavač**

Članovi Povjerenstva za ocjenjivanje i obranu završnog rada:

1. dr.sc. Zoran Vrhovski, predsjednik
2. Tomislav Pavlic, mag.ing.mech., mentor
3. Danijel Radočaj, mag.inž.meh., član

2. ZADATAK ZAVRŠNOG RADA BROJ: 07/MEH/2021

U radu je potrebno:

- opisati osnovne principe i elemente industrijske robotike, obrade odvajanjem čestica i elektropneumatike;
- izraditi i opisati elektropneumatske sheme industrijskog robota, pneumatske prihvatnice, kompresora i glavnog vretena za glodanje;
- opisati offline simulacijske programske alate za industrijske robote koji se koriste za obradu odvajanjem čestica i paletizaciju;
- napraviti simulaciju glodanja i paletizacije industrijskim robotom korištenjem offline simulacijskog programskog alata;
- pustiti sustav u rad;
- napraviti upute za siguran rad sa sustavom.

Zadatak uručen: 27.09.2021.

Mentor: **Tomislav Pavlic, mag.ing.mech.**



Zahvala

Izuzetno se zahvaljujem svome mentoru dr. sc. Tomislavu Pavlicu, mag. ing. mech., na svom uloženom trudu, znanju i pomoći prilikom izrade ovog završnog rada. Zahvaljujem se Danijelu Radočajju, mag. ing. meh. za pomoć u radu s robotom. Firmi FESTO za izlaženje u susret u području pneumatike i elektropneumatike. Posebno se zahvaljujem svojim roditeljima Nadici i Željku, te sestri Ivani na podršci i strpljenju tijekom studiranja.

SADRŽAJ

1.	UVOD	1
1.1.	PODRIJETLO I ZNAČENJE RIJEČI ROBOT I ROBOTIKA.....	1
1.2.	OPĆENITO O ROBOTICI	3
1.2.1.	<i>Industrijska robotika</i>	3
2.	INDUSTRIJSKI ROBOTI	5
2.1.	PREDNOSTI ROBOTA U INDUSTRIJSKOJ PROIZVODNJI	6
2.2.	GEOMETRIJA RADNOG PROSTORA	9
2.2.1.	<i>TTT ili pravokutna konfiguracija</i>	10
2.2.2.	<i>RTT ili cilindrična konfiguracija</i>	11
2.2.3.	<i>RRT ili sferna konfiguracija</i>	12
2.2.4.	<i>SCARA konfiguracija</i>	13
2.2.5.	<i>RRR ili rotacijska konfiguracija</i>	14
2.3.	NAČINI UPRAVLJANJA GIBANJEM	15
2.3.1.	<i>Kretanje od točke do točke (eng. Point-to-point motion)</i>	15
2.3.2.	<i>Kontinuirano kretanje po putanji (eng. Continuous path)</i>	15
2.4.	PROGRAMIRANJE I VOĐENJE INDUSTRIJSKIH ROBOTA	15
2.4.1.	<i>Programski jezici za robote</i>	16
2.4.2.	<i>Prednosti off-line programiranja robota</i>	17
2.4.3.	<i>Ručno vođenje (eng. Jogging)</i>	18
2.5.	DEFINIRANJE TCP-A	29
2.6.	DEFINIRANJE RADNOG KOORDINATNOG SUSTAVA (ENG. WORK OBJECT)	30
2.7.	OPĆENITE ZNAČAJKE ROBOTA	31
2.8.	INDUSTRIJSKI ROBOT ABB IRB 120	33
2.8.1.	<i>Kontroler robota Compact IRB5C</i>	38
2.8.2.	<i>Upravljačka palica FlexPendant</i>	39
2.8.3.	<i>Kalibracija manipulatora</i>	40
3.	OSNOVE GLODANJA	47
3.1.	GLODANJE	47
3.2.	GIBANJE GLODALA	48
3.2.1.	<i>Koordinatni sustav</i>	48
3.2.2.	<i>Brzina rezanja</i>	49
3.2.3.	<i>Brzina posmaka</i>	50
3.3.	G-KOD	51
3.3.1.	<i>Programska struktura</i>	51
3.3.2.	<i>Zaglavlje programa</i>	52
3.3.3.	<i>Adrese F, S, T, D, M</i>	53
3.3.4.	<i>Naredbe gibanja G0, G1, G2, G3</i>	53
3.3.5.	<i>Kompenzacija putanje alata</i>	53
3.3.6.	<i>Informacije o alatu – glodalu</i>	54
3.3.7.	<i>Korišteno glavno vreteno u radu</i>	54
4.	ELEKTROPNEUMATIKA	56
4.1.	KORIŠTENI KOMPRESOR	57
4.2.	KORIŠTENI PNEUMATSKA PRIHVATNICA	58
4.2.1.	<i>Karakteristike korištene prihvatnice</i>	58
5.	REALIZACIJA PROJEKTA GLODANJA INDUSTRIJSKIM ROBOTOM	60
6.	ZAKLJUČAK	61
7.	LITERATURA	62
8.	OZNAKE I KRATICE	64

9.	SAŽETAK.....	65
10.	ABSTRACT	66
11.	PRILOZI	67

1. UVOD

1.1. Podrijetlo i značenje riječi robot i robotika

Riječ robot (od slavenske riječi robota, što znači posao), prvi se puta pojavljuje u javnosti češkog književnika Karel-a Čapek-a u svojoj drami R.U.R. (eng. Rossum's Universal Robots) iz 1920. godine. Radnja drame počinje u tvornici koja proizvodi umjetna stvorenja, nalik pravim ljudima, nazvane robotima.



Slika 1.1. Rossum-ovi univerzalni roboti

Svibnja 1941. godine u znanstveno-fantastičnoj pripovijetci „Liar“, Isaac Asimov prvi put koristi riječ robotika (eng. robotics). Asimov nije bio svjestan da smišlja termin; budući da je znanost i tehnologija elektroničkih uređaja elektronika, pretpostavio je da se robotika već odnosi na znanost i tehnologiju robota.

U nekim drugim Asimovljevim djelima, on navodi da je prva upotreba riječi robotika bila u njegovoj pripovijetci „Runaround“, gdje je predstavio svoj koncept Tri zakona robotike (eng. Three Laws of Robotics) koji su glasili:

- 1. robot ne smije ozlijediti čovjeka ili, ničim izazvan, dopustiti čovjeku da se ozlijedi*
- 2. robot mora slušati naredbe koje mu je dao čovjek, osim ako bi takve naredbe bile kontradiktorne prvom zakonu*
- 3. robot mora štiti sebe sve dok takva zaštita nije kontradiktorna prvom ili drugom zakonu*

Međutim, izvorna objava pripovijetke „Liar“ prethodi pripovijetci „Runaround“, pa se „Liar“ navodi kao podrijetlo te riječi.

Dakle, robot je stvar koja pomaže ljudima u svakodnevnom životu i obavlja poslove umjesto čovjeka, a robotika znanost koja se bavi izradom i proučavanjem istih. [1]

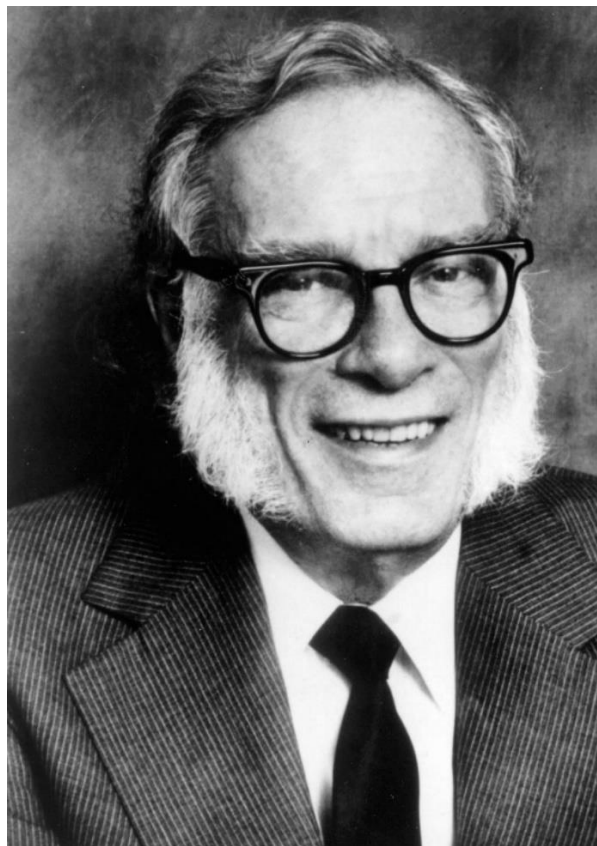

Slika 1.2. Issac Asimov

1.2. Općenito o robotici

- **Industrijska robotika**

- Stacionarni roboti (robotske ruke)
- Teži izradi preciznijih i bržih robota
- Razvoj industrijske robotike usmjeruju i određuju industrijske potrebe
- Standardizacija u izvedbi robota i industrijske okoline koja ga okružuje

- **Mobilna robotika**

- Zamjena čovjeka kod opasnih poslova (otkrivanje i deaktiviranje mina, pregled nuklearnog reaktora, pregled uskladištenog otpada, pregled cijevi, ispitivanje visokonaponskih vodova)
- Upotreba u vojne svrhe (izviđanja)
- Svemirska istraživanje
- Filmska industrija
- Zabava i edukacija

1.2.1. Industrijska robotika

- Industrijska robotika je okosnica fleksibilne automatizacije čiji je cilj povećanje:
 - Produktivnosti
 - Kvalitete proizvoda
 - Fleksibilnosti
 - Kvalitete i sigurnosti ljudskog rada
- Industrijske robote odlikuje:
 - Visoki stupanj programibilnosti tj. da se bez fizičke intervencija mogu promijeniti kretnje i funkcija robota
 - Fleksibilnost tj. mogućnost primjena za različite zadatke sa ili bez fizičkih intervencija
 - Inteligencija tj. sposobnost da robot sam odlučuje o akcijama koje treba poduzeti

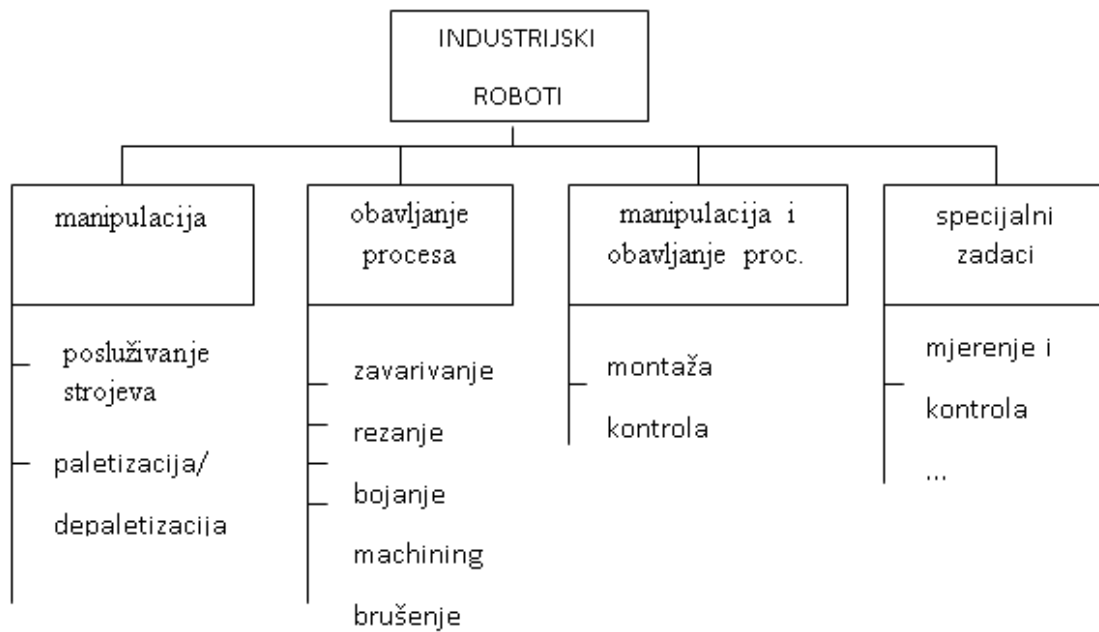

Slika 1.3. Podjela industrijskih robota



Slika 1.4. Paleta industrijskih robota i kontrolera proizvođača ABB

2. INDUSTRIJSKI ROBOTI

Roboti obavljaju razne zadatke te su konstruirani tako da zamjene čovjeka ili mu pomognu u svakodnevnim napornim, opasnim i monotonim poslovima. Postoje humanoidni roboti, oni koji liče čovjeku i imitiraju ga, razni kućanski roboti (npr. za usisavanje kućanskog i uredskog prostora) te oni industrijski koji se koriste u proizvodnji. Pod terminom robot, najčešće se podrazumijeva pojam industrijski robot, robotska ruka ili robotski manipulator. Pojam industrijskog robota definiran je standardom ISO 8373 [2], kao uređaj s automatskom kontrolom, višenamjenski manipulator s tri ili više osi odnosno više stupnjeva slobode gibanja te se da reprogramirati. Neke od uloga industrijskog robota su zavarivanje, obrada odvajanjem čestica (npr. glodanje, bušenje, poliranje, rezanje i sl.), sastavljanje, pakiranje, bojanje, paletiziranje, ispitivanje proizvoda i drugo. Sve uloge robota moraju biti obavljene s visokom preciznošću, brzinom te roboti moraju biti pouzdani i izdržljivi. Najzastupljenija područja upotrebe industrijskih robota su u automobilskoj, farmaceutskoj i prehrambenoj industriji. Roboti se dijele prema generacijama koje su definirane po složenosti informatičkog sustava i stupnju inteligencije. Prema [3] dijele se na 3 generacije:

- **roboti 1. generacije (programski roboti)**
 - karakterizira ih čisto upravljanje
 - nemaju osjetila i niske su inteligencije
 - najrašireniji su jer su jednostavni i zadovoljavajuće rješavaju problem rukovanja
- **roboti 2. generacije (adaptivni roboti)**
 - opremljeni su raznim sensorima i sustavima prepoznavanja
 - senzori šalju informacije te se jednostavnom logikom ugrađenom u računalo rješavaju zadatci
 - krajnji cilj robota je da pomiče predmete
- **roboti 3. generacije (inteligentni roboti)**
 - koriste računala nove generacije
 - vode procese s više ulaznih i izlaznih varijabli
 - robot sam reagira odnosno sam donosi odluke uspoređujući s dobivenim informacijama izvana

2.1. Prednosti robota u industrijskoj proizvodnji

- Smanjenje operativnih troškova
- Poboljšanje kvalitete proizvoda
- Poboljšanje kvalitete rada djelatnika
- Povećanje produktivnosti
- Povećanje fleksibilnosti proizvodnje
- Smanjenje otpadnog materijala i povećanje prometa
- Pridržavanje sigurnosnih pravila i zaštite na radu
- Smanjenje fluktuacije radne snage i teškoća pri zapošljavanju radnika
- Smanjenje kapitalnih troškova
- Ušteda prostora u proizvodnim pogonima

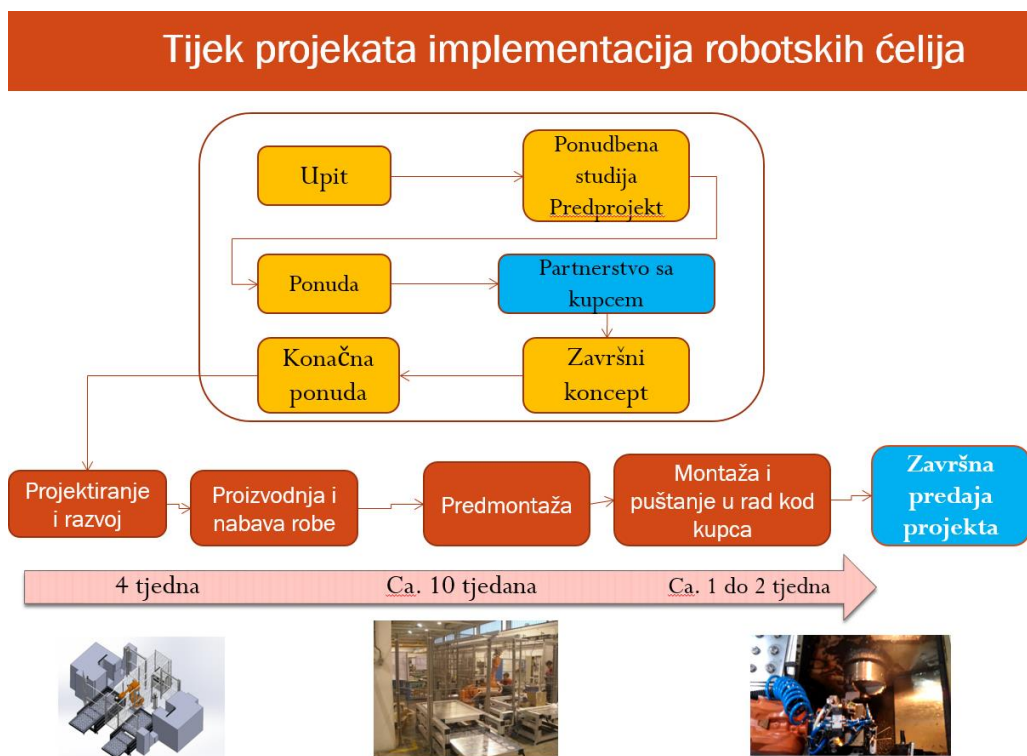

Slika 2.1. Tijek projekata implementacije robotskih ćelija

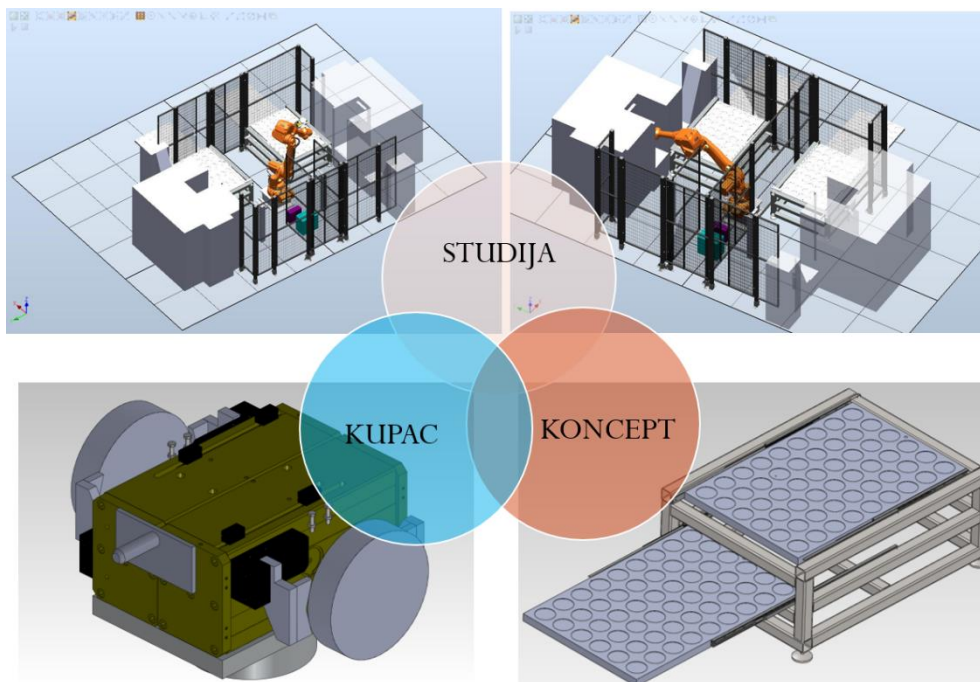

Slika 2.2. Tijek razvoja robotskih rješenja

IZRADA ZAVRŠNOG KONCEPTA

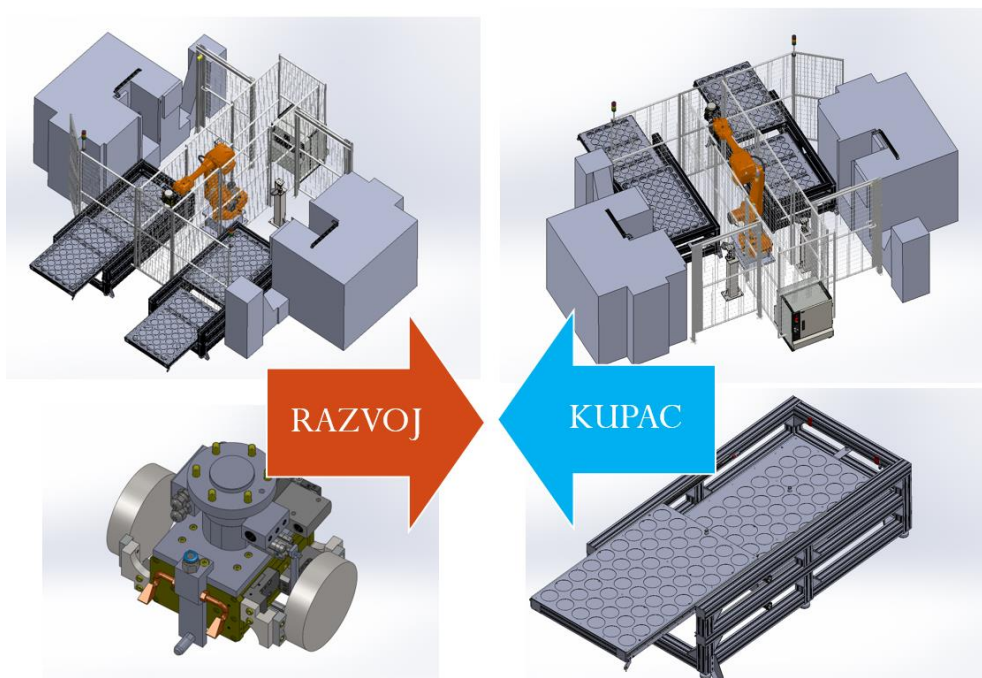

Slika 2.3. Izrada završnog koncepta



Slika 2.4. Posluživanje strojeva

2.2. Geometrija radnog prostora

Veličina radnog prostora robota, odnosno skup točaka u trodimenzionalnom prostoru koje ručni zglob robota može dohvatiti, ovisi o duljinama članaka, broju i tipu zglobova robota te o fizičkim ograničenjima koja su povezana s građom i izgledom robota. [4]

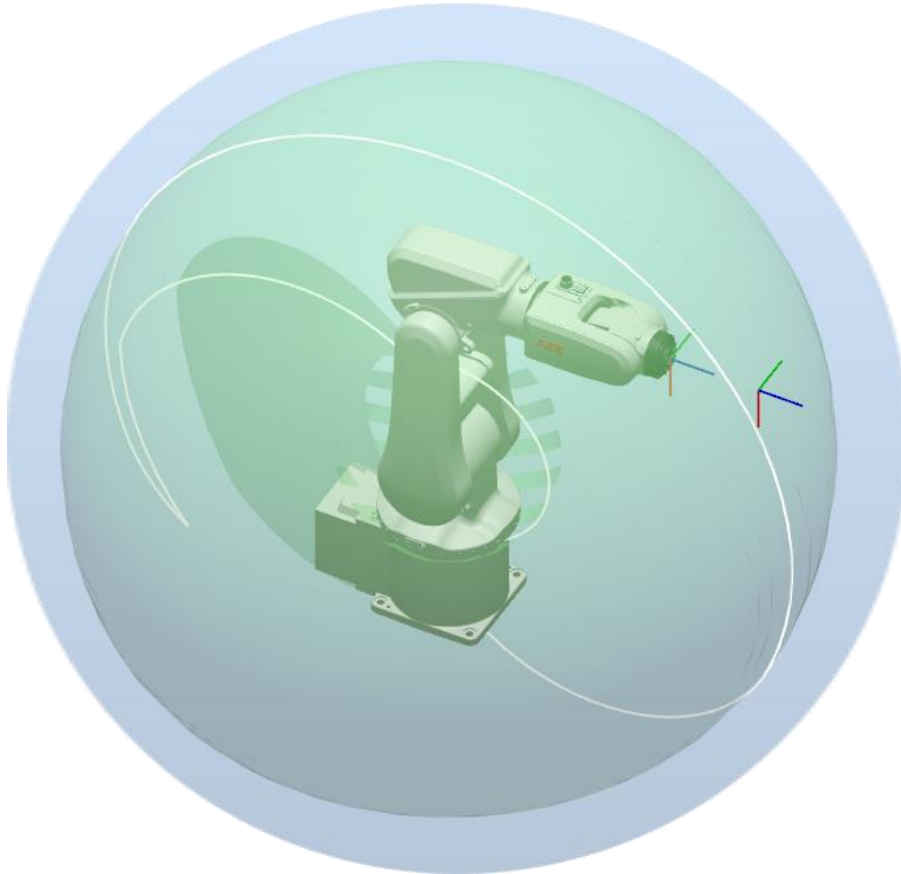

Slika 2.5. Geometrija radnog prostora robotskog manipulatora ABB IRB 120

Geometrija radnog prostora robotskog manipulatora (kombinacija rotacijskih (R) i translacijskih (T) zglobova za prve tri osi) dijeli se na:

- TTT ili pravokutna (eng. Cartesian or rectangular)
- RTT ili cilindrična (eng. cylindrical)
- RTT ili sferna (eng. spherical)
- SCARA koja može biti tipa RTR, TRR, RTT
- RRR ili rotacijska (eng. articulated)

2.2.1. TTT ili pravokutna konfiguracija

Pravokutna konfiguracija robota sastoji se od tri translacijska zgloba čije su osi međusobno okomite. Budući da se radi o pravocrtном kretanju i jednostavnoj geometriji, svaki stupanj pokretljivosti podudara se sa stupnjem slobode u Kartezijском porstoru. Prednosti takve konfiguracije su dobra mehanička čvrstoća, točnost pozicioniranja ručnog zgloba je konstantna, a nedostatak je slaba pokretljivost zato što su svi zglobovi translacijski. Najčešće se koristi kod rukovanja materijalima pri montaži.

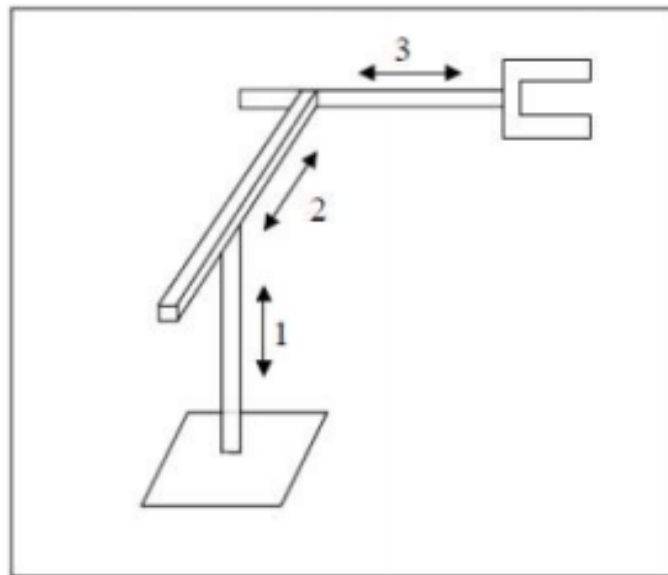

Slika 2.6. TTT ili pravokutna konfiguracija [5]

2.2.2. RTT ili cilindrična konfiguracija

Ukoliko se zamjeni prvi zglob pravokutne konfiguracije rotacijskim zglobom, dobit će se robot cilindrične konfiguracije. Prednosti takve konfiguracije su dobra mehanička čvrstoća, a nedostaci ne tako dobra točnost pozicioniranja ručnog zgloba ukoliko se poveća horizontalni hod. Uglavnom koristi hidrauličke motore kao pogon za zglobove češće nego električne i upotrebljava se za prijenos objekata većih dimenzija.

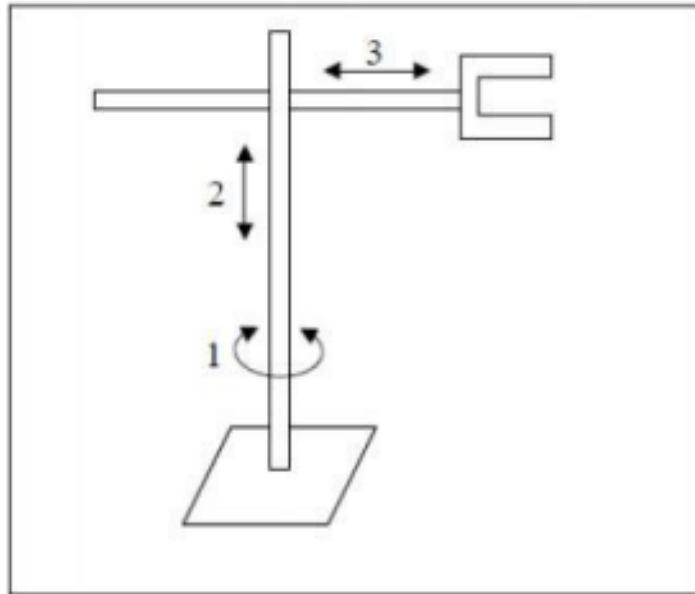

Slika 2.7. RTT ili cilindrična konfiguracija [5]

2.2.3. RRT ili sferna konfiguracija

Zamjenom drugog zgloba cilindrične konfiguracije robota dobit će se robot sferne konfiguracije. Što se tiče mehaničke čvrstoće, ona je manja u odnosu na pravokutnu i cilindričnu konfiguraciju zbog složenosti geometrijske i mehaničke konstrukcije. S porastom radijalnog hoda smanjuje se točnost pozicioniranja. Uglavnom se koristi u strojarskoj industriji i obično se koriste električni motori za pokretanje kod pokretanja zglobova robota.

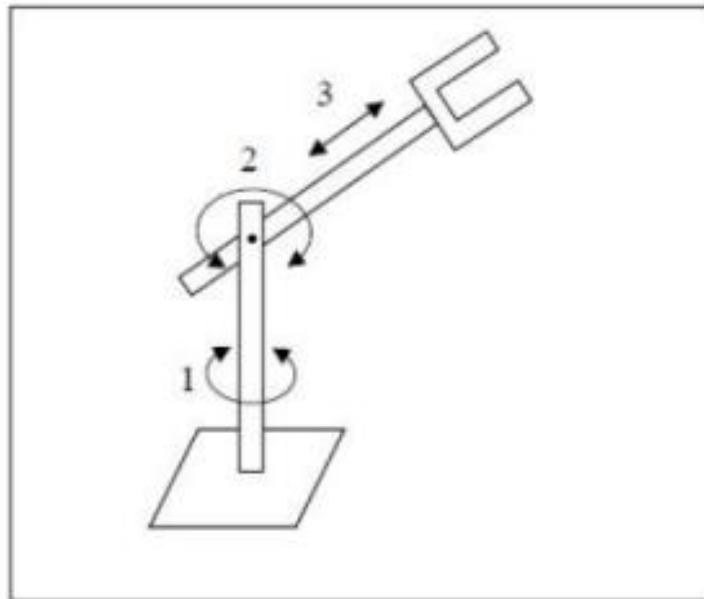

Slika 2.8. RRT ili sferna konfiguracija [5]

2.2.4. SCARA konfiguracija

Roboti tipa SCARA (eng. Selective Compliance Assembly Robot Arm) također imaju dva rotacijska i jedan rotacijski zglobov, kao kod sferne konfiguracije, no kod takvih postoje tri različite konfiguracije RTR, TRR, RTT. SCARA koristi sve tri vertikalne osi, a kod sferne zadnja os horizontalna te se zbog toga SCARA koristi za zadatke montiranja po vertikalnoj osi. Karakterizira ga visoka čvrstoća za opterećenje na vertikalnoj osi, no popustljivost za opterećenja u horizontalnoj osi.

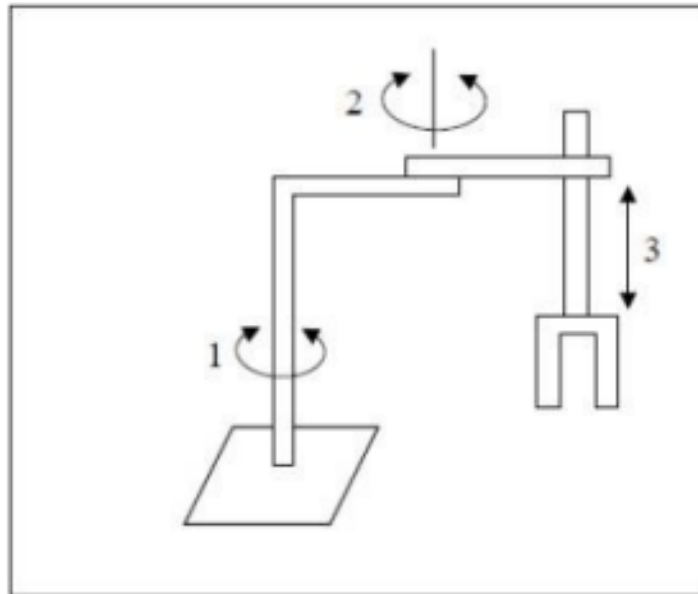

Slika 2.9. SCARA konfiguracija [5]

2.2.5. RRR ili rotacijska konfiguracija

Rotacijska konfiguracija koristi sva tri rotacijska zgloba čije su osi rotacije drugog i trećeg zgloba paralelne i okomite na os rotacije prvog zgloba. Ukoliko ne postoje ograničenja tada je radni prostor robota kugla. Za pogon zglobova se koriste elektromotori i područje primjene je raznoliko.[5]

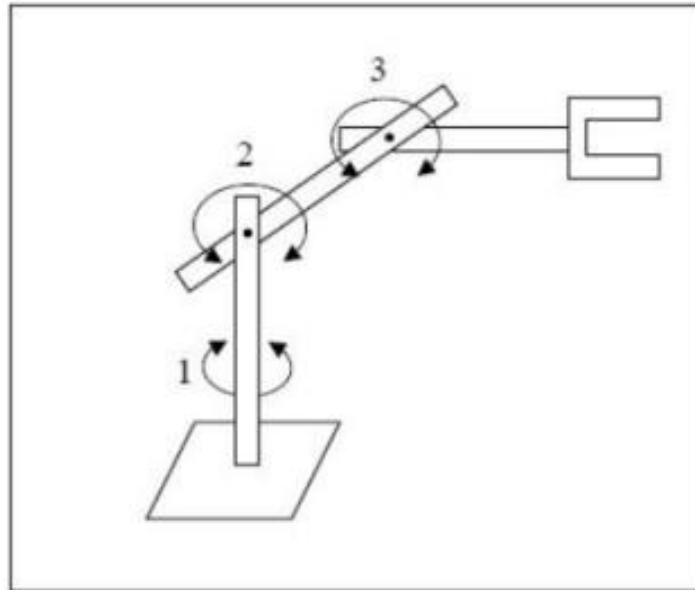

Slika 2.10. RRR ili rotacijska konfiguracija [5]

2.3. Načini upravljanja gibanjem

Prema kretanju vrha manipulatora, roboti se dijele na dva osnovna načina:

2.3.1. Kretanje od točke do točke (eng. Point-to-point motion)

Kretanje od točke do točke izvršava se tako da je cilj završnog mehanizma kretati se po željenim koordinatama u radnom prostoru uz veliku točnost i brzinu pozicioniranja te nije važna putanja kojom će se robot kretati. Kao takvo koristi se kod operacija koje su diskretne (npr. točkasto zavarivanje, podizanje i spuštanje predmeta).

2.3.2. Kontinuirano kretanje po putanji (eng. Continuous path)

Kontinuiranim kretanjem po putanji završni mehanizam giba se po pred definiranoj putanji te je pri tome bitan put kretanja i točnost pozicioniranja. Koristi se kod zadataka poput glodanja i lijepljenja.

2.4. Programiranje i vođenje industrijskih robota

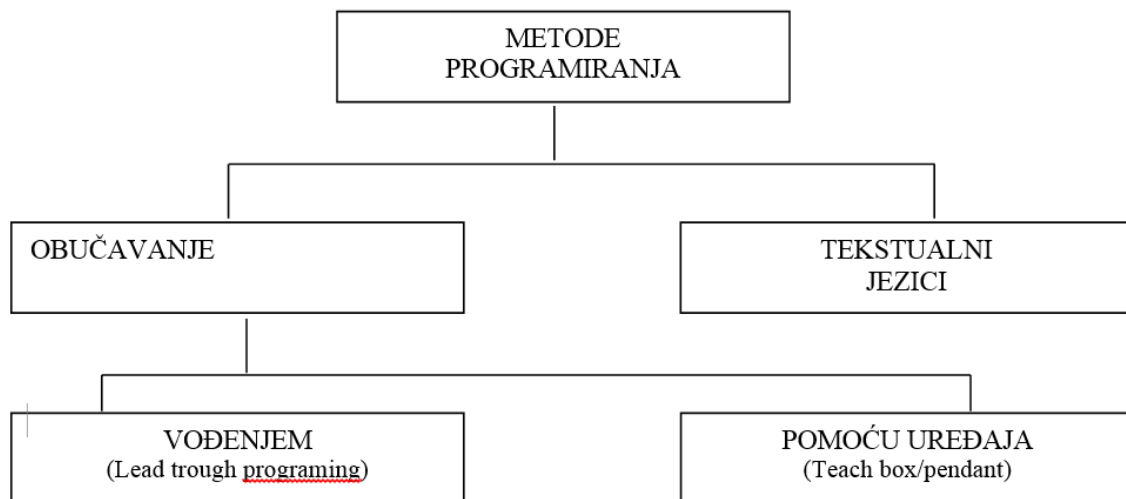

Slika 2.11. Metode programiranja

2.4.1. Programski jezici za robote

Pri programiranju složenih projekata gdje su potrebne tisuće točaka klasično programiranje vođenjem (obučavanjem) nije moguće te su zbog toga razvijeni robotski programski jezici koji omogućuju *off-line* programiranje.

- VAL 3 (Adept & Staubli)
- ROBOFORTH
- RAPID (ABB)
- PDL2 (Comau)
- Karel (Fanuc)
- KRL (Kuka)
- Inform (Yaskawa)

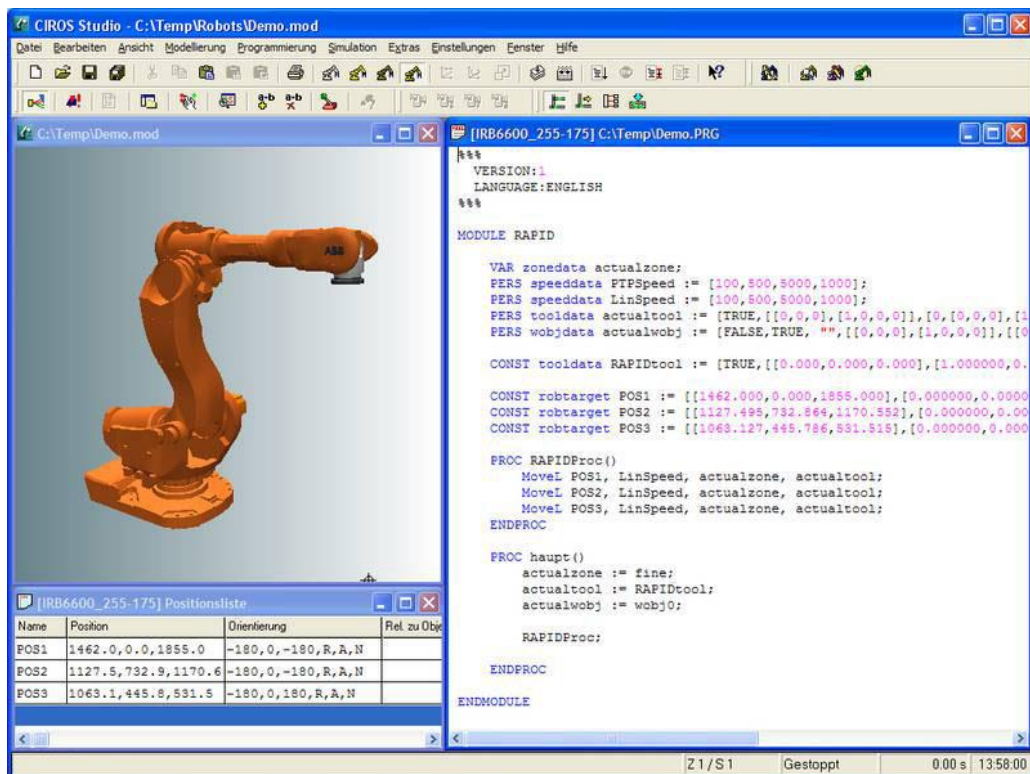

Slika 2.12. Izgled RAPID (ABB) programskog jezika

2.4.2. Prednosti off-line programiranja robota

- Program se priprema bez korištenja robota odnosno zaustavljanja proizvodnje
- Novi programi mogu koristiti prethodno razvijene rutine
- Programi se lako i brzo mijenjaju
- Lako se u logiku programa uključuju informacije senzora i ostalih kompleksnih sustava
- Program je moguće kreirati iz podataka viših razina kao što je CAD
- Moguće su grafičke simulacije i provjere programa
- Program s minimalnim brojem podataka može biti korišten za različite robota uz primjenu različitih post procesora



Slika 2.13. ABB Robotstudio

2.4.3. Ručno vođenje (eng. Jogging)

Postupak pri kojem programer ili operater upravlja pozicijama manipulatora putem upravljačke palice. Na taj način obavljaju se razni zadaci robotom:

- Pokretanje programa
- Pomicanje manipulatora
- Izmjene programa
- Komunikacija s perifernim uređajima



Slika 2.14. ABB Teach pendant

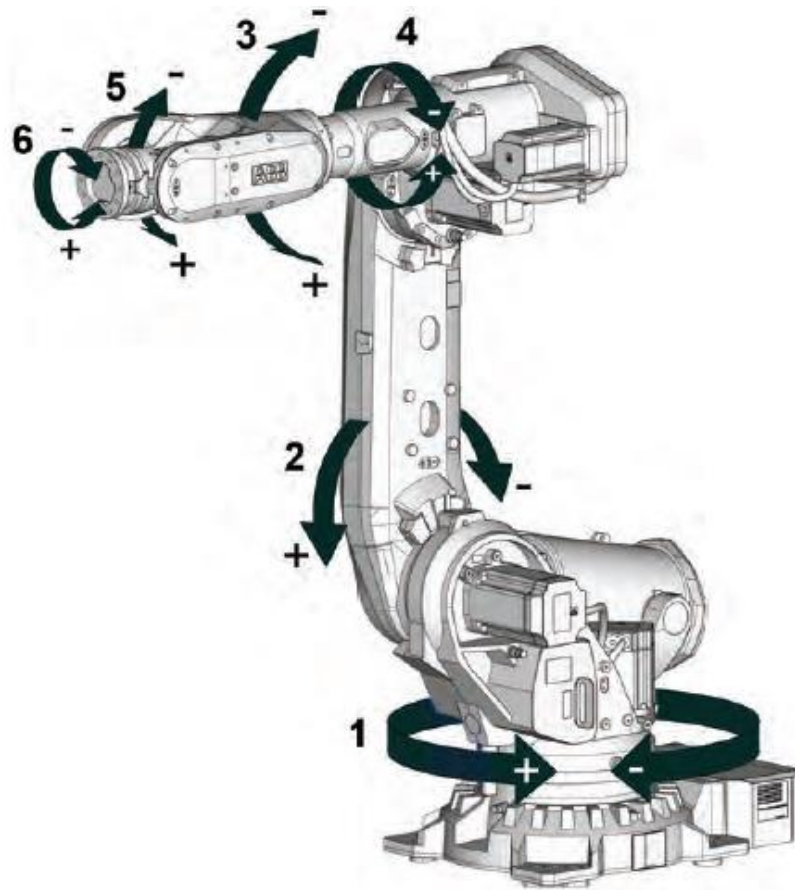

Slika 2.15. „Jogging“ po osima

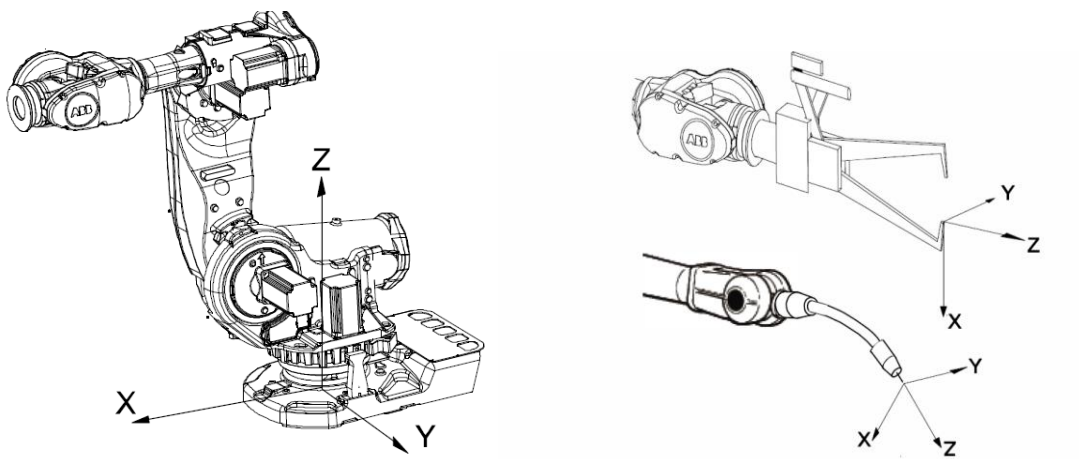

Slika 2.16. Linearan „jogging“

These are the main parts of the FlexPendant.



xx1400001636

A	Connector
B	Touch screen
C	Emergency stop button
D	Joystick
E	USB port
F	Enabling device
G	Stylus pen
H	Reset button

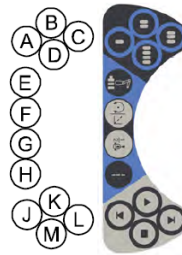

xx0900000023

A - D	Programmable keys, 1 - 4. How to define their respective function is detailed in section Programmable keys..
E	Select mechanical unit.
F	Toggle motion mode, reorient or linear.
G	Toggle motion mode, axis 1-3 or axis 4-6.
H	Toggle increments.
J	Step BACKWARD button. Executes one instruction backward as button is pressed.
K	START button. Starts program execution.
L	Step FORWARD button. Executes one instruction forward as button is pressed.
M	STOP button. Stops program execution.

Slika 2.17. Programiranje i ručno vođenje ABB robota putem FlexPendants

- HotEdit izbornik – koristi se za izmjenu programiranih pozicija

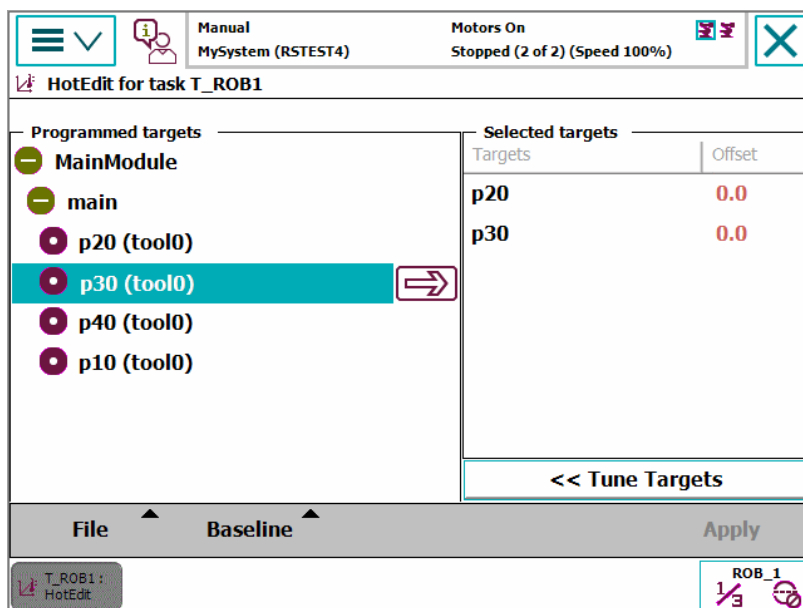

Slika 2.18. HotEdit izbornik

- FlexPendant Explorer – file manager sličan Windows Explorer-u kojim se manipulira datotekama na kontroleru.

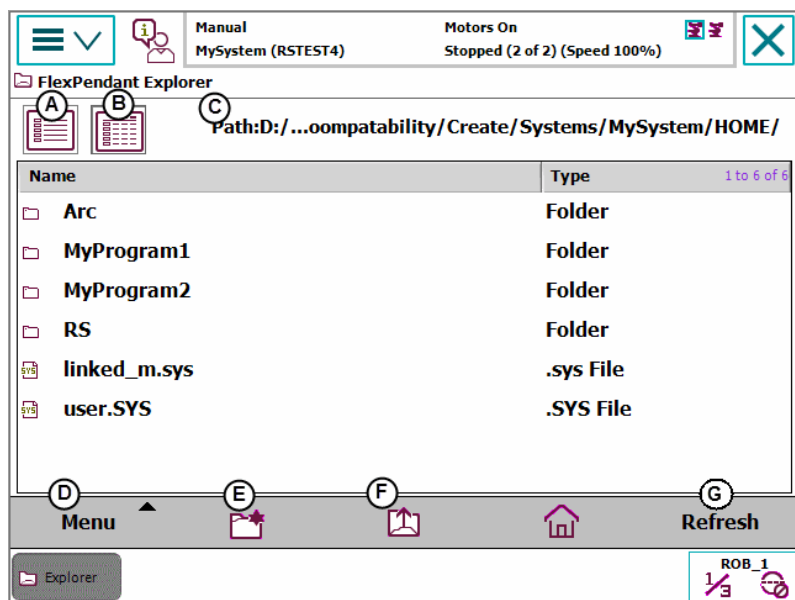

- A** – Jednostavan pogled
- B** – Detaljan pogled
- C** – Lokacija
- D** – Izbornik
- E** – Nova mapa
- F** – Promjena reda mape
- G** – Osvježi

Slika 2.19. Izgled FlexPendant Explorer-a

- I/O signals – izbornik za podešavanje ulaznih/izlaznih signala. Iz izbornika je moguće i simulirati ulazne/izlazne signale.

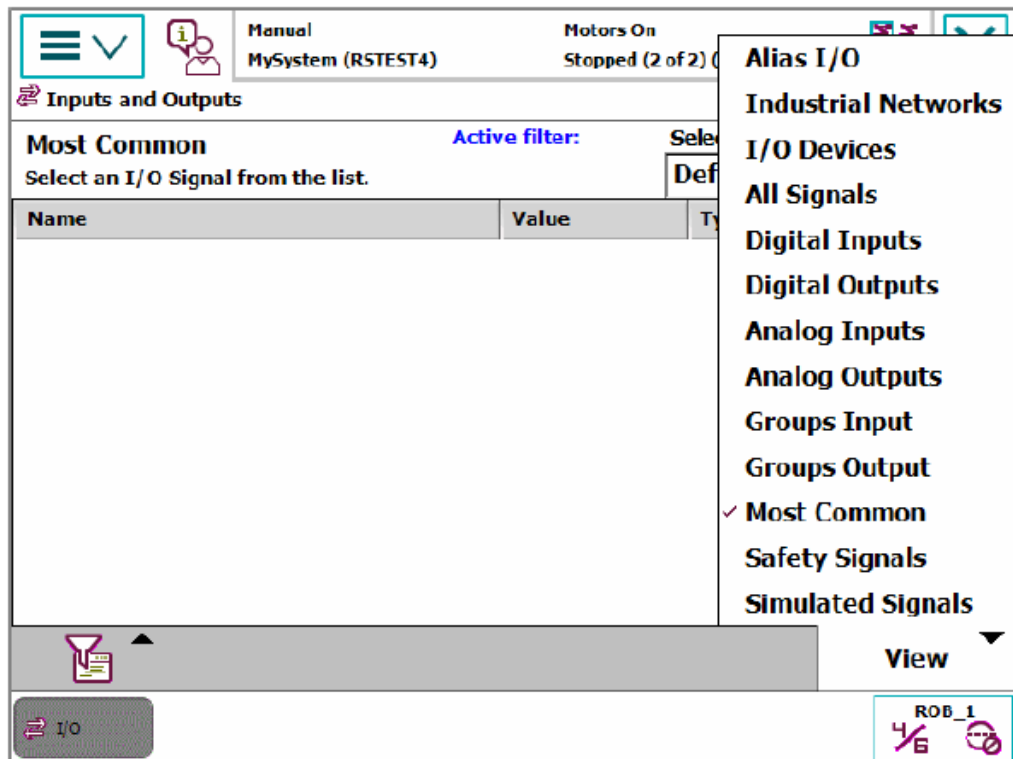

Slika 2.20. I/O signals izbornik

- Jogging izbornik – izbornik za preko kojeg se ručno vodi robot.

Mechanical unit – odabir manipulatora kojom se upravlja

Absolute accuracy – upali/ugasi AbsAcc opciju

Motion mode – odabir načina ručnog vođenja

Coordinate system – Odabir koordinatnog sistema kojim se vodi

Tool – odabir alata

Work object – odabir radnog koordinatnog sustava

Payload – odabir tereta

Joystick lock – zaključavanje upravljačke palice u određenom smjeru gibanja

Increment – Odabir inkrementalnog pomaka

Position – prikaz pozicija

Position format – Odabir formata prikaza pozicije

Joystick directions – prikaz smjera upravljačke palica

Align – poravnavanje alata s odabranim koordinatnim sus.

Go To – Pomicanje robota na odabranu poziciju

Activate – Aktiviranje manipulatora

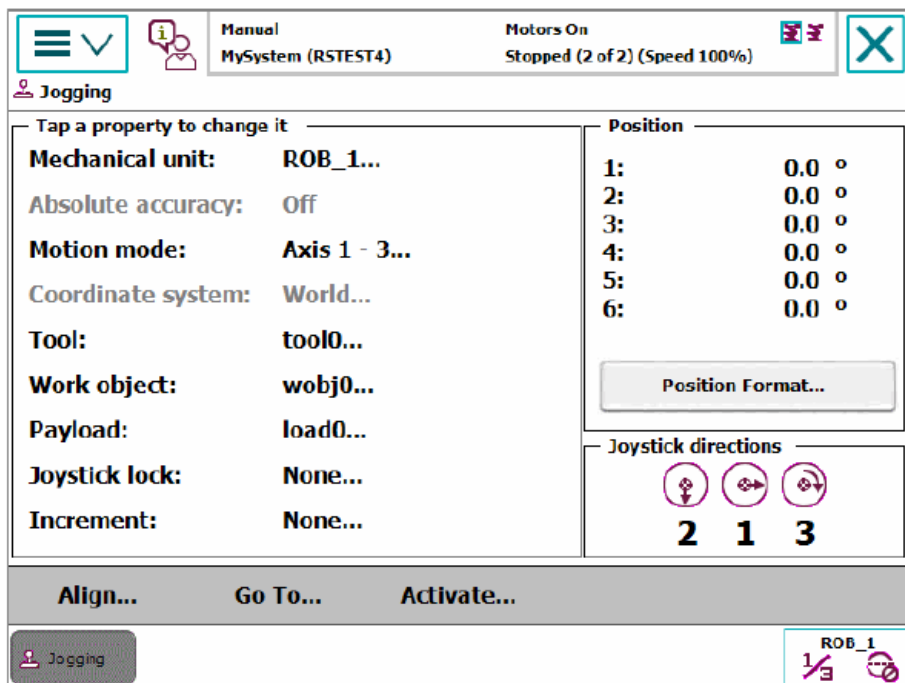

Slika 2.21. Jogging izbornik

- Production izbornik – izbornik preko kojeg se pregledava kod programa koji se izvodi.

Load Program – učitavanje novog programa

PP to Main – Pomicanje točke izvođenja programa na Main rutinu

Debug – Debug izbornik je dostupan samo u ručnom radu

The screenshot shows the 'Production Window' interface. At the top, there are status indicators: 'Manual', 'MySystem (RSTEST4)', 'Motors On', and 'Stopped (2 of 2) (Speed 100%)'. The main window title is 'Production Window : MyProgram1 in T_ROB1/MainModule/main'. The left pane shows a tree view with 'T_ROB1' and 'T_ROB2'. The right pane displays the following code:

```

4  CONST robtarget p30:=[ [515.00,0.00,712.
5  CONST robtarget p40:=[ [515.00,0.00,712.
6  CONST robtarget p50:=[ [515.00,0.00,712.
7  TASK PERS tooldata tool1:=[TRUE,[[0,0,0
8  TASK PERS wobjdata wobj1:=[FALSE,TRUE,"
9  PROC main()
10 MoveL p10, v1000, z50, tool0;
11 MoveL p20, v100, z15, tool0;
12 WaitDI DI1, 1;
13 MoveL p30, v100, z15, tool0;
14 WaitDI DI2, 1;
15 MoveL p40, v100, z15, tool0;
16 MoveL p10, v100, z15, tool0;
17 ENDPROC

```

At the bottom, there are buttons for 'Load Program...', 'PP to Main', and 'Debug'. A 'Production Window' button is also visible on the left, and a 'ROB_1' control panel is on the right.

Slika 2.22. Production izbornik

- Program Editor – služi za pisanje i izmjenu programa. Moguće je otvoriti više od jednog prozora Program Editora.

Tasks and Programs – izbornik za programske operacije

Modules – Lista svih modula

Routines – Lista svih rutina

Add Instruction – Dodavanje instrukcije

Edit – Otvaranje *Uredi* izbornika

Debug – Funkcije za pomicanje točke izvođenja programa, servisne rutine itd..

Modify Position – Izbornik za izmjenu pozicija programa

Hide Declarations – Olakšava čitanje programa

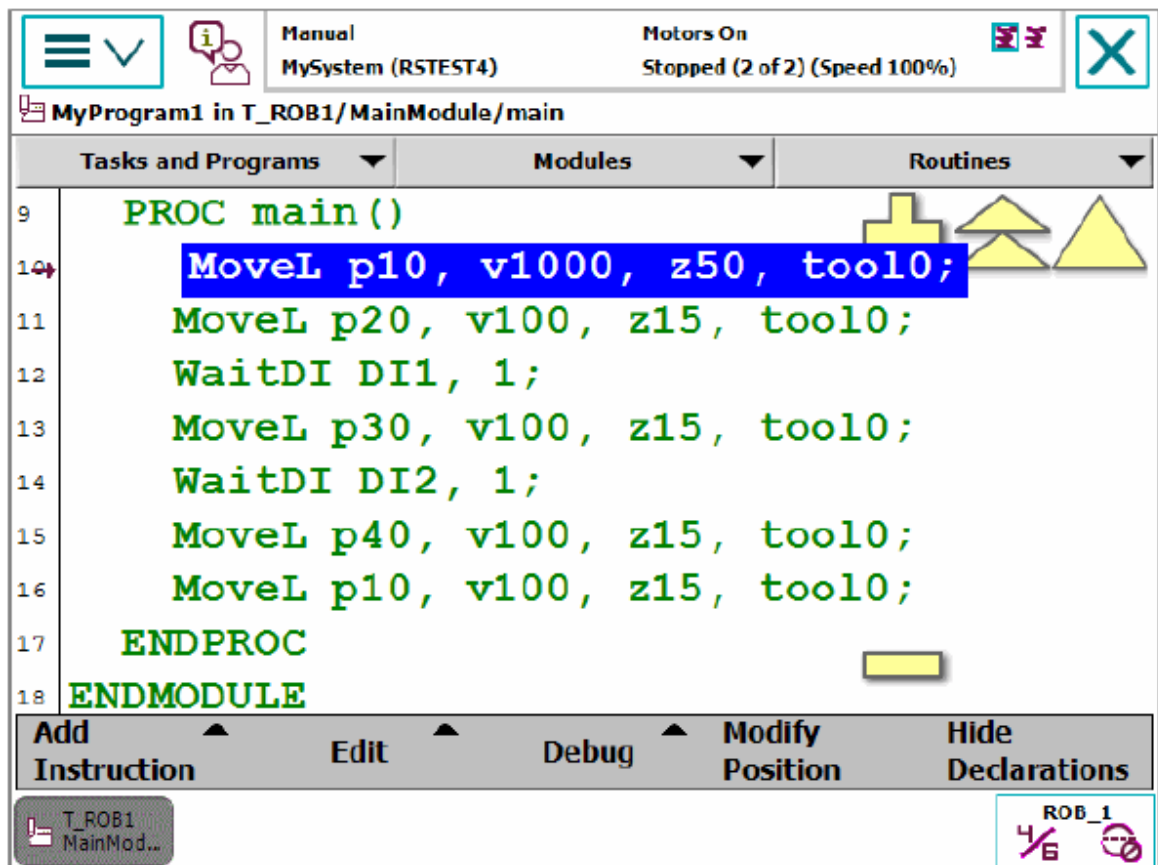

Slika 2.23. Program Editor

- Control Panel – Izbornik za podešavanje i prilagodbu robotskog sistema i upravljačke jedinice FlexPendant-a.

Appearance – Prilagodba ekrana i izgleda sučelja

Supervision – Izbornik za podešavanje parametra kretnje manipulatora

FlexPendant– Prilagodba korisničkih prava

I/O – Prilagodba najviše korištenih I/O signala

Language – Promjena jezika

ProgKeys – Podešavanje 4 programibilne tipke na FlexPendant-u

Date and Time – Postavke vremena i datuma

Configuration – Podešavanje sistemskih parametara

Touch Screen – Rekalibriranje ekrana osjetljivog na dodir

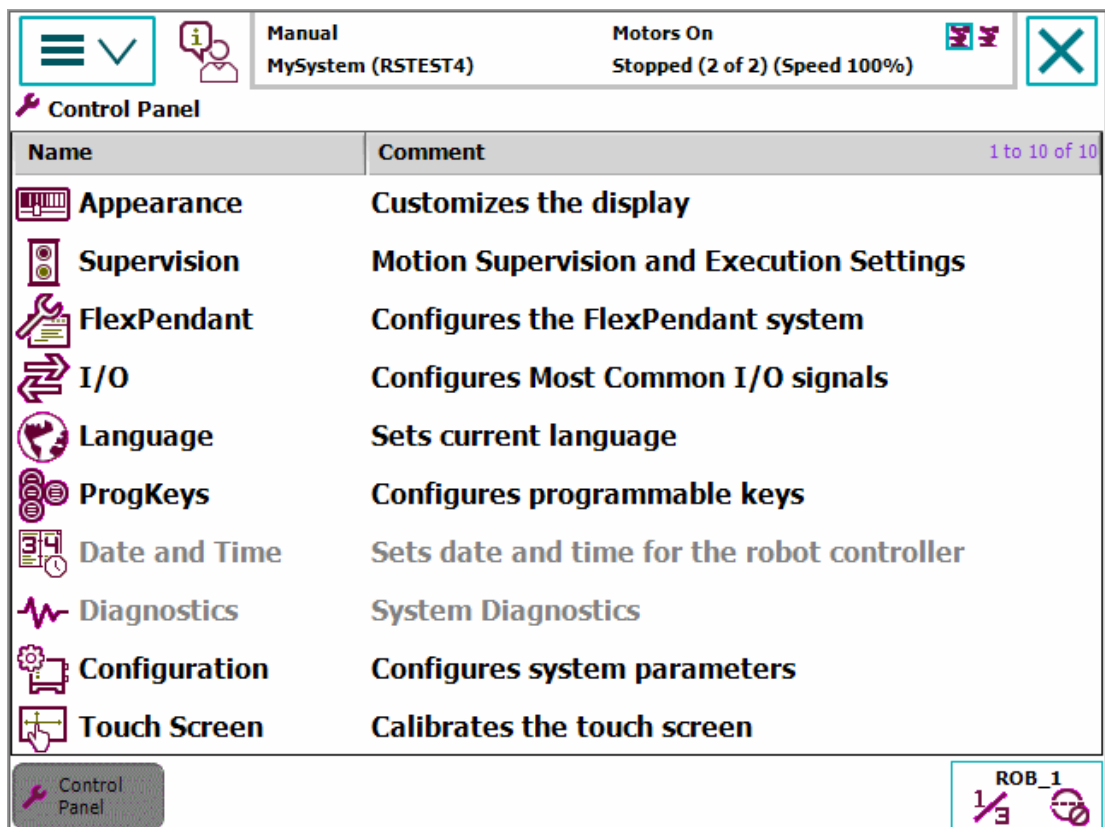

Slika 2.24. Control Panel

- Event Log – Izbornik za prikaz zapisa rada robotskog sistema

Manual MySystem (RSTEST4) Motors On Stopped (2 of 2) (Speed 100%)

Event Log - Common

Tap a message to open it.

Code	Title	Date & Time
i 10002	Program pointer has been reset	2014-08-06 11:17:19
i 10011	Motors ON state	2014-08-06 11:14:47
i 10010	Motors OFF state	2014-08-06 11:14:46
i 10002	Program pointer has been reset	2014-08-06 11:14:08
i 10002	Program pointer has been reset	2014-08-06 11:11:19
i 10015	Manual mode selected	2014-08-06 11:10:55
i 10012	Safety guard stop state	2014-08-06 11:10:55
i 10011	Motors ON state	2014-08-06 11:10:50
i 10017	Automatic mode confirmed	2014-08-06 11:10:49

Save All Logs As... Delete Update View

Program Data I/O ROB_1

Slika 2.25. Event Log

- Programiranje i ručno vođenje ABB robota putem FlexPendanta: Quickset menu – Izbornik koji olakšava ručni rad s robotskim sistemom i omogućuje jednostavnije ručno vođenje upravljačkom palicom.

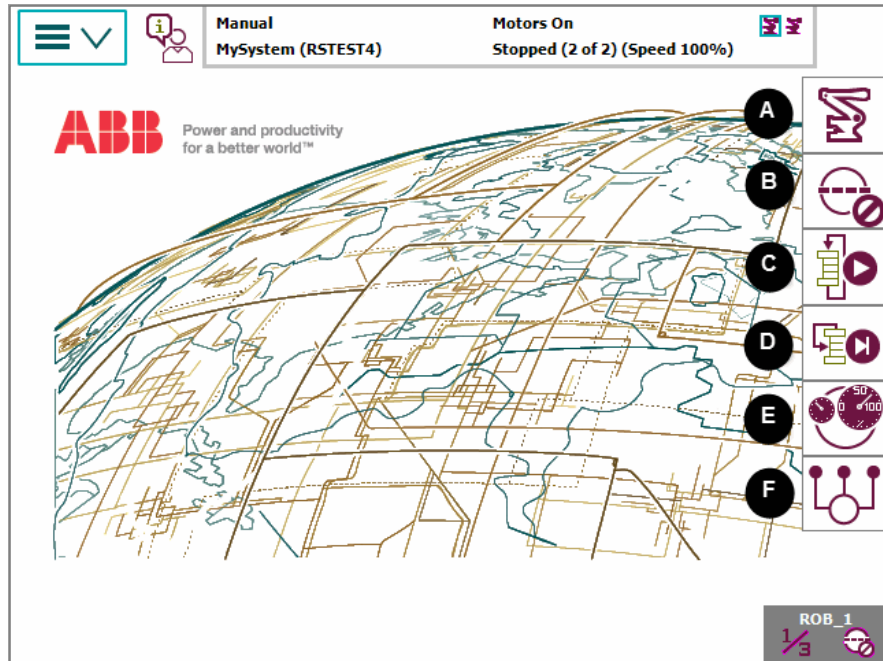

- A – Manipulator
- B – Inkrementalno vođenje
- C – *Run Mode*
- D – *Step mode*
- E – Podešavanje brzine
- F – Zadaci

Slika 2.26. Quickset menu početni zaslou

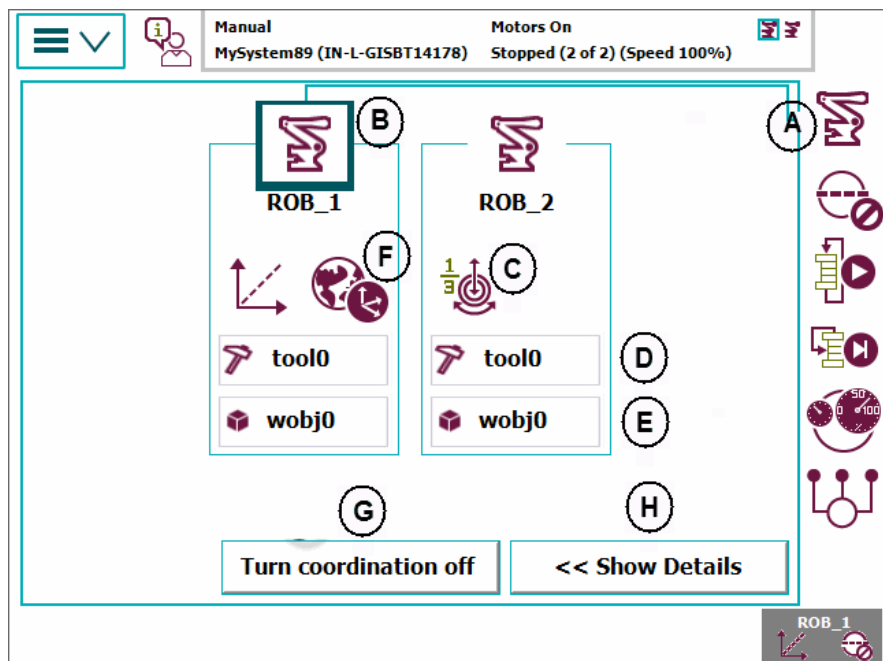

- A – Manipulator izbornik
- B – Izbor manipulatora
- C – *Motion mode* izbornik
- D – Postavke alata
- E – Postavke radnog koordinatnog sustava
- F – Odabir koordinatnog sustava za vođenje
- G – Isključivanje koordinatnog vođenja
- H – Prikaz više detalja

Slika 2.27. Quickset menu izbornik manipulatora

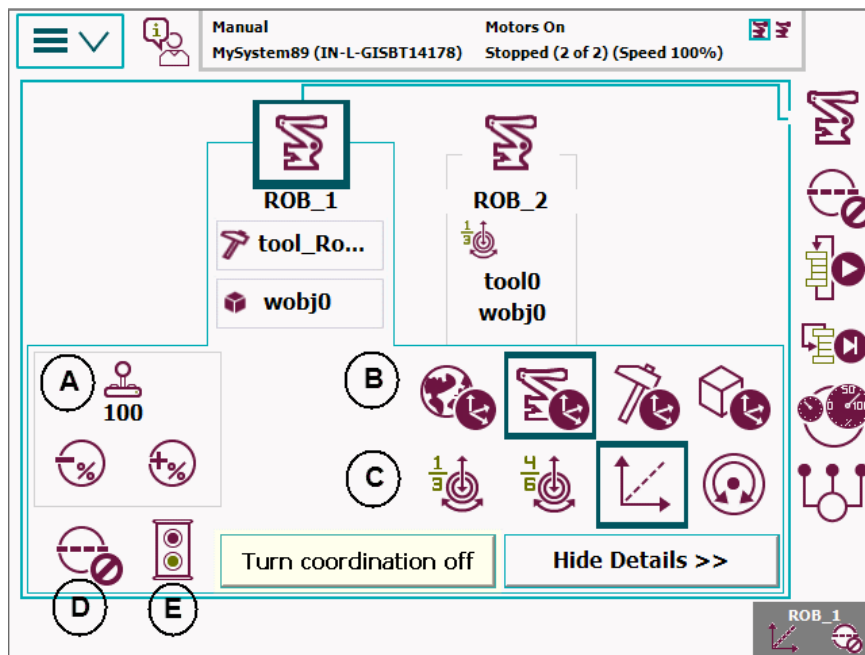

- A – Override brzine ručnog vođenja
- B – Podešavanja koordinatnog sustava
- C – Postavke kretanja
- D – Inkrementalni pomak
- E – Nadgledanje ručnog vođenja

Slika 2.28. Quickset menu dodatni parametri

2.5. Definiranje TCP-a

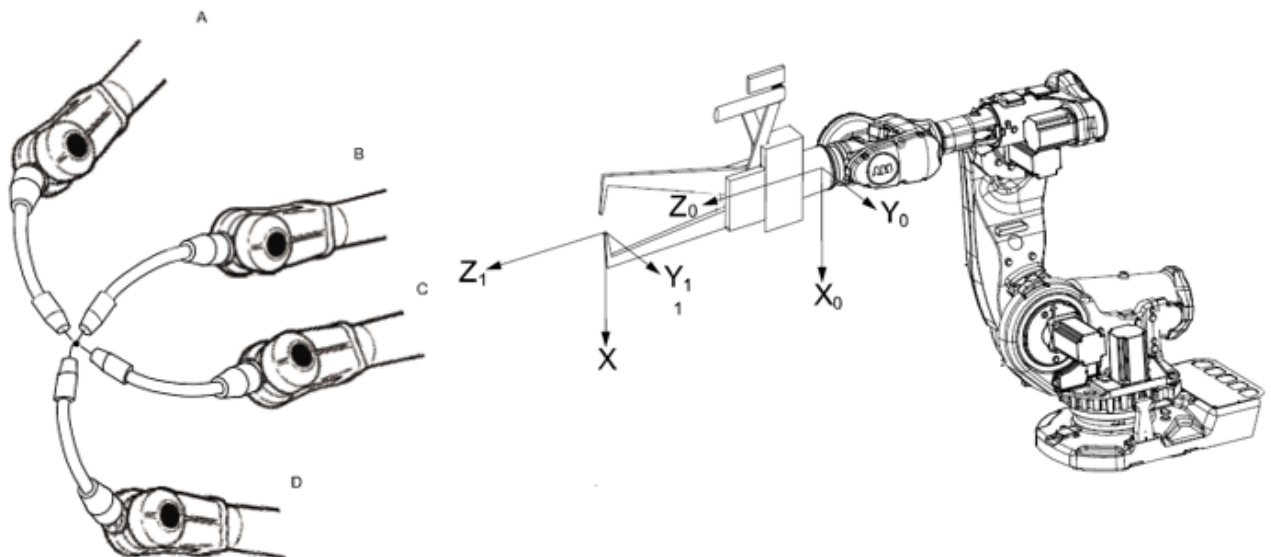

Slika 2.29. Prikaz definiranja TCP-a

2.6. Definiranje radnog koordinatnog sustava (eng. Work Object)

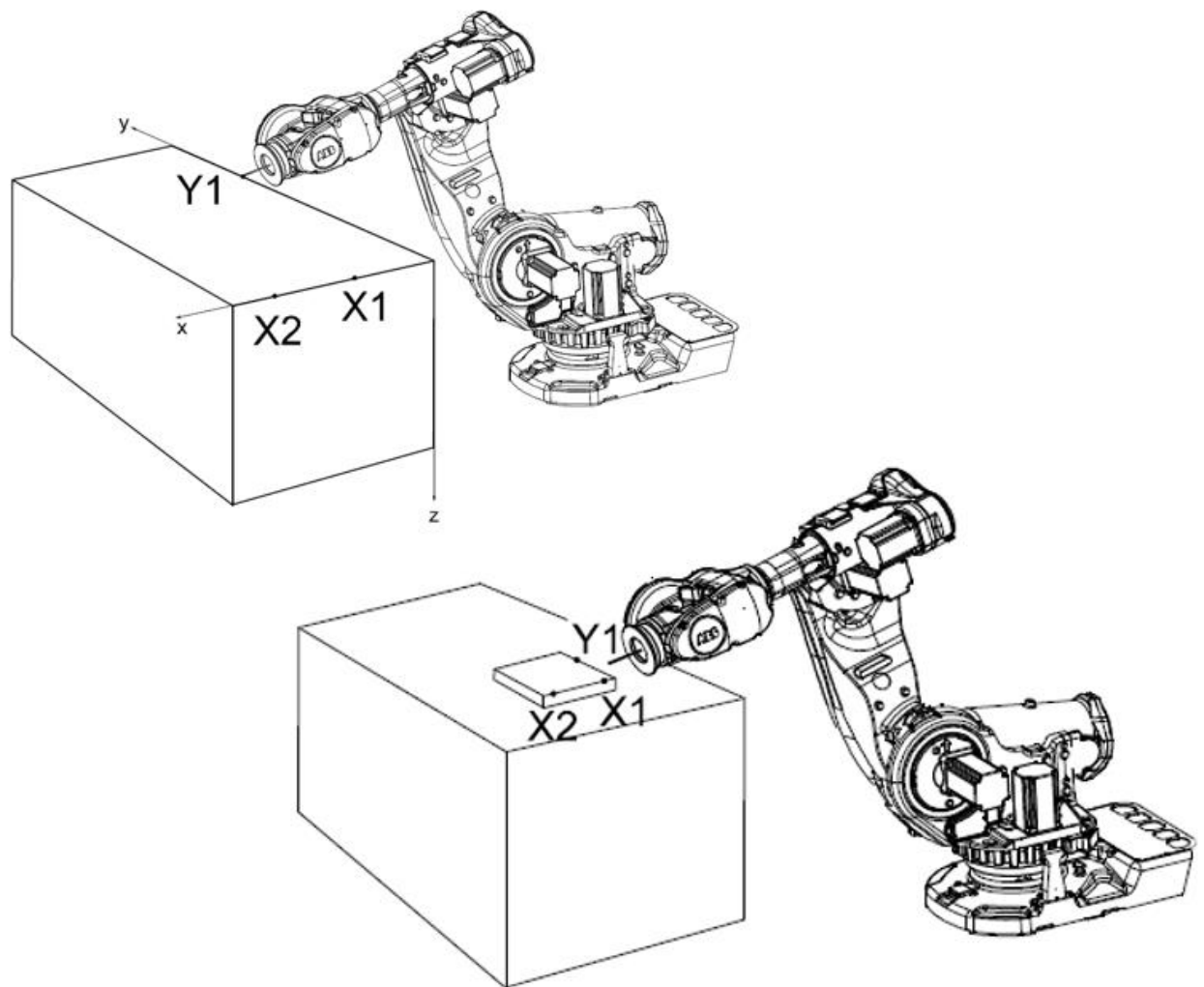

Slika 2.30. Prikaz definiranja radnog koordinatnog sustava (eng. Work Object)

2.7. Općenite značajke robota

- **broj osi** - kako bi se dosegla bilo koja točka u ravnini, potrebne su dvije osi. Tri osi su potrebne da bi se dosegla bilo koja točka u prostoru, a za potpunu kontrolu orijentacije vrha robota, odnosno robotskog manipulatora, potrebno je još tri osi.
- **stupnjevi slobode** - obično ih označava broj i vrsta osi.
- **radni prostor** - skup svih točaka u prostoru koje robot može dosegnuti.
- **struktura robota** - opisuje vrste članova koji određuju moguća gibanja robota.
- **nosivost robota** - nazivna masa s kojom robot može manipulirati.
- **brzina** - opisuje vrijeme potrebno da robot pozicionira izvršni tj. alatni koordinatni sustav u željenu poziciju.
- **ubrzanje** - opisuje koliko brzo robot može ubrzati promjenu pozicije.
- **preciznost** - opisuje s kojim odstupanjem se robot pozicionira u zadanu poziciju.
- **ponovljivost** - opisuje s kojom preciznošću se robot vraća u programiranu poziciju.
- **kontrola kretnji** - ovisno o zadatku koji robot izvršava, kretnje moraju biti isključivo kontinuirane (npr. glodanje) ili nekog drugog oblika.
- **vrsta pogonske sile** - vrste pogonskih motora i aktuatora u zglobovima robota.
- **prijenos** - postoje direktni spojevi na zglobove i preko mjenjačkih mehanizama.
- **propustljivost** - značajka koja opisuje manje promjene položaja kod velikog opterećenja robota.

- Kartezijski roboti
 - povoljno radno područje
 - veliki roboti
 - skuplja izrada
 - manje brzine
- SCARA roboti
 - krutost u vetikalnom smjeru
 - popustljivost u horizontalnoj ravnini
 - velike brzine
 - povoljni za montažu
- 6-osni roboti – vertikalna zglobna konfiguracija
 - velika fleksibilnost
 - mali i srednji roboti
 - najzastupljeniji
- Paralelni ili Delta roboti
 - visoka krutost i preciznost
 - velike brzine
 - povoljni za pick&place

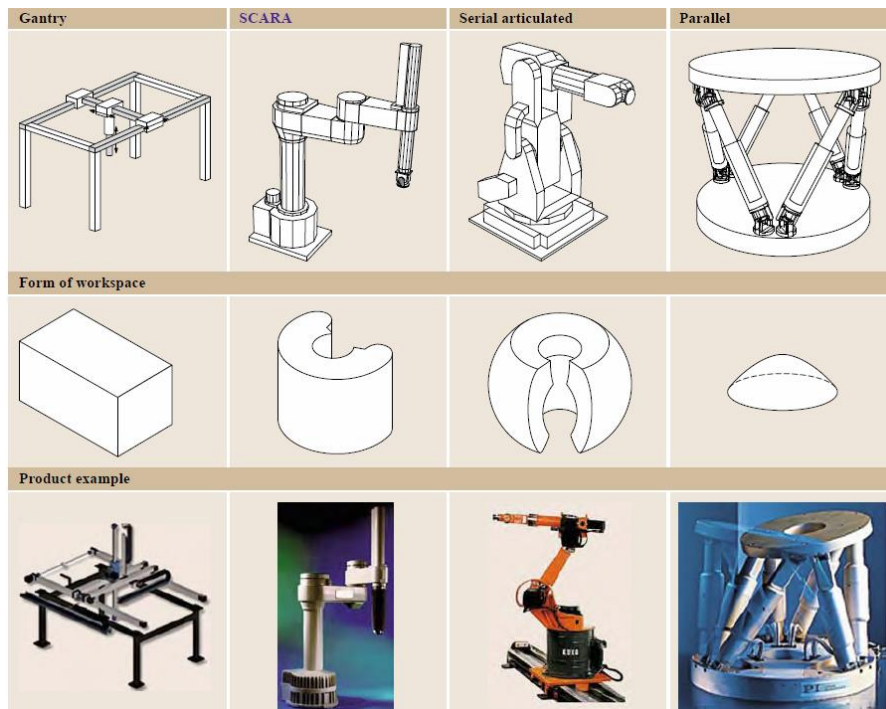

Slika 2.31. Prikaz najčešćih kinematika industrijskih robota

2.8. Industrijski robot ABB IRB 120

ABB IRB 120 je industrijski robot najnovije četvrte generacije robotske tehnologije švicarsko-švedske tvrtke ABB (Asea Brown Boveri), koja se pretežito bavi energetikom i automatizacijom. Prezentira ga se kao okretno, kompaktno i lagano rješenje s izuzetno pouzdanom kontrolom i točnošću, stoga je idealan za baratanje s predmetima i zadatke u industriji gdje se zahtjeva stroga preciznost i kvaliteta. Sastoji se od ABB IRB 120 robotskog manipulatora (robotske ruke), PLC kontrolera Compact IRB5C i upravljača nazvanog FlexPendant. Konfiguracija robota je rotacijska (RRRRRR), točnije to je manipulator sa šest osi. Izuzetno je precizan jer posjeduje 6 koračnih elektromotora s ugrađenim enkoderima i kočnicama. Teži 25 kilograma i nosivost mu je 3 kilograma. Dizajniran je specifično za proizvodnu industriju koja koristi automatizaciju baziranu na robotima (npr. industrija 3C). Zasnovan je na standardu ISO 10218-1:2011. [6]

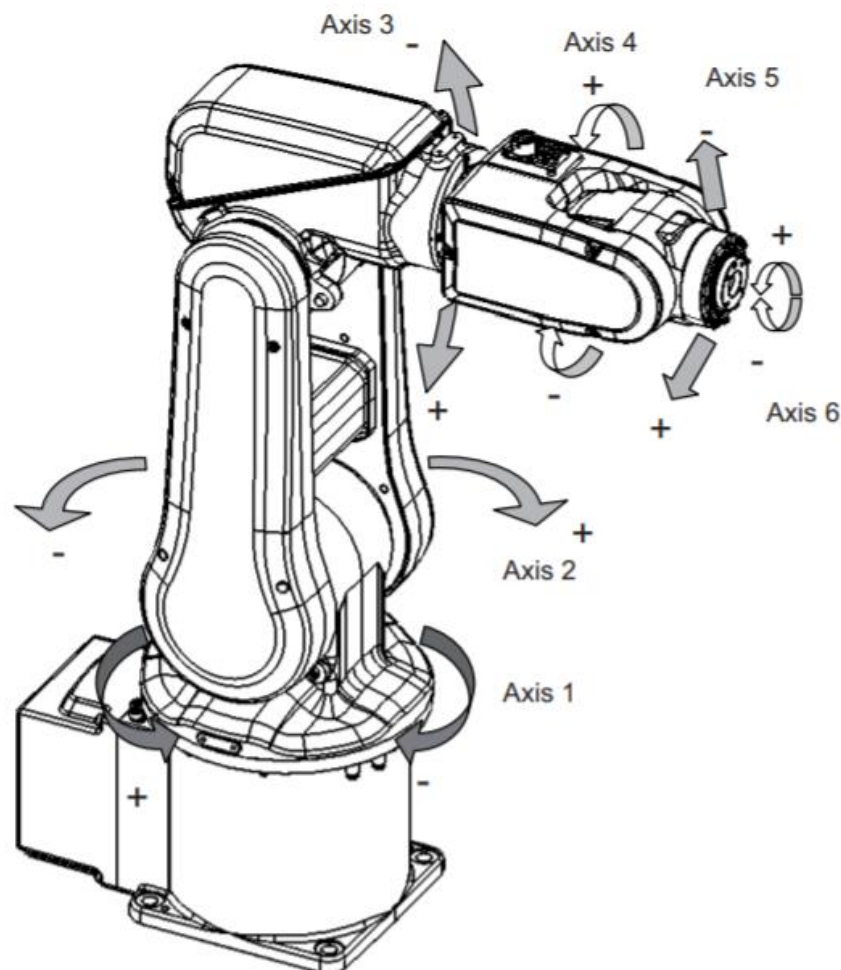

Slika 2.32. Definicije osi ABB IRB 120 robota [6]

Tablica 2.1. Standardi prema ISO 10218-1 [6]

Normative standards as referred to from ISO 10218-1

Standard	Description
ISO 9283:1998	Manipulating industrial robots - Performance criteria and related test methods
ISO 10218-2	Robots and robotic devices - Safety requirements for industrial robots - Part 2: Robot systems and integration
ISO 12100	Safety of machinery - General principles for design - Risk assessment and risk reduction
ISO 13849-1:2006	Safety of machinery - Safety related parts of control systems - Part 1: General principles for design
ISO 13850	Safety of machinery - Emergency stop - Principles for design
IEC 60204-1:2005	Safety of machinery - Electrical equipment of machines - Part 1: General requirements
IEC 62061:2005	Safety of machinery - Functional safety of safety-related electrical, electronic and programmable electronic control systems

Other standards used in design

Standard	Description
ISO 9787:2013	Robots and robotic devices -- Coordinate systems and motion nomenclatures
IEC 61000-6-2	Electromagnetic compatibility (EMC) – Part 6-2: Generic standards – Immunity standard for industrial environments
IEC 61000-6-4 (option 129-1)	Electromagnetic compatibility (EMC) – Part 6-4: Generic standards – Emission standard for industrial environments
ISO 13732-1:2008	Ergonomics of the thermal environment - Part 1
IEC 60974-1:2012 ⁱ	Arc welding equipment - Part 1: Welding power sources
IEC 60974-10:2014 ^j	Arc welding equipment - Part 10: EMC requirements
ISO 14644-1:2015 ⁱⁱ	Classification of air cleanliness
IEC 60529:1989 + A2:2013	Degrees of protection provided by enclosures (IP code)

Working range

The illustration shows the unrestricted working range of the robot.

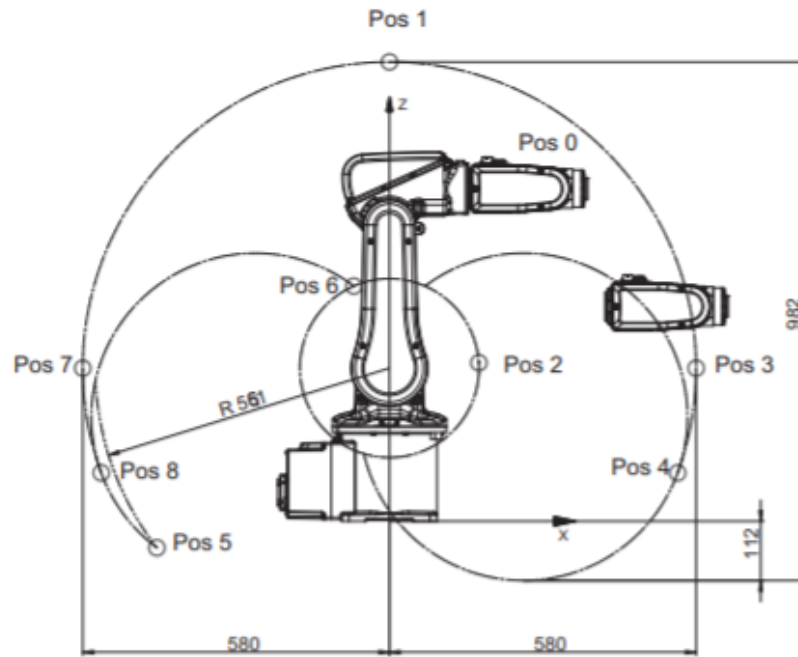

xx0900000263

Position	Position at wrist center (mm)		Angle (degrees)	
	X	Z	Axis 2	Axis 3
A	302 mm	630 mm	0°	0°
B	0 mm	870 mm	0°	-77°
C	169 mm	300 mm	0°	+70°
D	580 mm	270 mm	+90°	-77°
E	545 mm	91 mm	+110°	-77°
F	-440 mm	-50 mm	-110°	-110°
G	-67 mm	445 mm	-110°	+70°
H	-580 mm	270 mm	-90°	-77°
J	-545 mm	91 mm	-110°	-77°

Slika 2.33. Radni prostor robotra ABB IRB 120 [6]

Tablica 2.2. Rotacijski domet manipulatora [6]

Robot motion

The table specifies the types and ranges of motion in every axes.

Location of motion	Type of motion	Range of movement
Axis 1	Rotation motion	+165° to -165°
Axis 2	Arm motion	+110° to -110°
Axis 3	Arm motion	+70° to -110°
Axis 4	Wrist motion	+160° to -160°
Axis 5	Bend motion	+120° to -120°
Axis 6	Turn motion	+400° to -400° (default) +242 revolutions to -242 re- volutions maximum ⁱ

Konektori su smješteni s gornje strane kućišta četvrte osi (konektor R3.CP/CS) i donje strane ispod kućišta prve osi (konektor R1.CP/CS) robotske ruke. Također posjeduje i 4 ulaza za stlačeni zrak (1/8") s donje strane i 4 izlaza (M5) s gornje strane. Svi kablovi i crijeva za zrak su ugrađeni unutar kućišta ruke. [7]

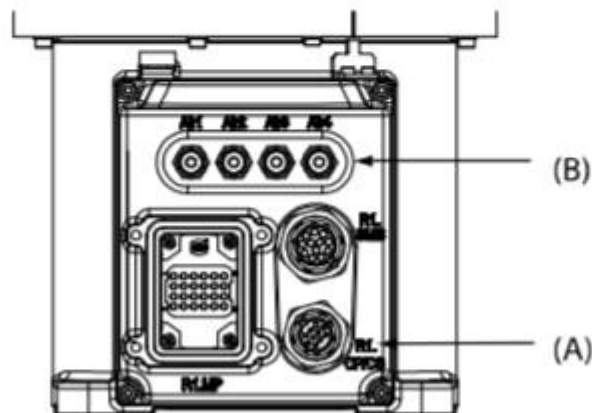
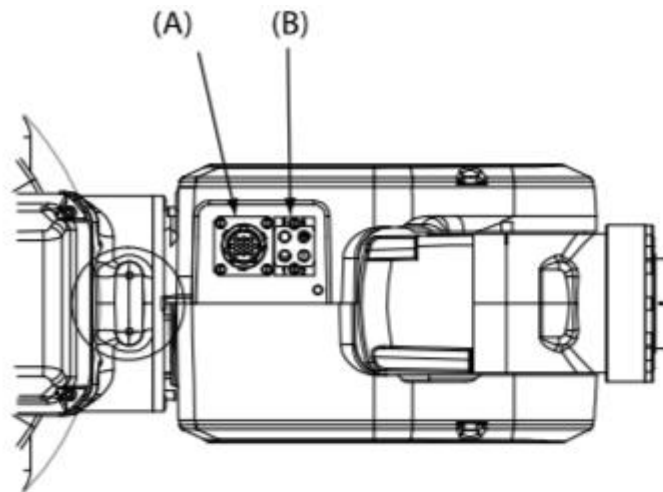

xx0900000264

Position	Connection	Description	Number	Value
A	(R1)R3.CP/CS	Customer power/signal	10	49 V, 500 mA
B	Air	Max. 5 bar	4	Outer diameter of air hose: 4 mm

Slika 2.34. Prikaz konektora [7]

2.8.1. Kontroler robota Compact IRB5C

Malen i kompaktan kontroler Compact IRB5C sadrži sve vanjske konektore za sve vrste signala i proširljiv 16 input 16 output I/O sistem (24 V). [8]

Specifikacije kontrolera:

- ima 16 ulaza i 16 izlaza (24 V)
- jednofazno napajanje od 220/230 V pri 50-60 Hz
- dimenzije 320*449*442 mm
- težina: 28.5 kg
- podrži temperaturu radnog prostora od 0 do 45 °C
- ima IP20 certifikat zaštite



Slika 2.35. Kontroler Compact IRB5C

2.8.2. Upravljačka palica FlexPendant

Kako bi operater i robot IRB 120 direktno komunicirali, bilo to manualno ili automatski, tu je upravljač FlexPendant. Karakterizira ga čist i šarolik zaslon na dodir s 3D palicom (eng. joystickom). [9]

Karakteristike:

- zaslon na dodir u boji
- 3D palica
- dvo-stupanjska membrana za pritisak
- 12 tipkala
- podržava USB
- rotacijski gumb u slučaju nezgode
- zaštićen IP54 standardom



Slika 2.36. Upravljačka palica FlexPendant [9]

2.8.3. Kalibracija manipulatora

Da bi robot bio pozicioniran na 0° na svih svojih 6 osi, potrebno ga je kalibrirati. Svaka os ima na svojem kućištu zarez ili neku oznaku da bi se tu nalazila neka sredina osi. Stoga je potrebno prebaciti robot u manualni rad te svaku os, pomoću gljive na upravljaču, preseliti u željeni položaj, odnosno poravnati s zarezima na kućištima osi.



Slika 2.37. Pozicija 0° za 1. os



Slika 2.38. Pozicija 0° za 2. os



Slika 2.39. Pozicija 0° za 3. os



Slika 2.40. Pozicija 0° za 4. os



Slika 2.41. Pozicija 0° za 5. os

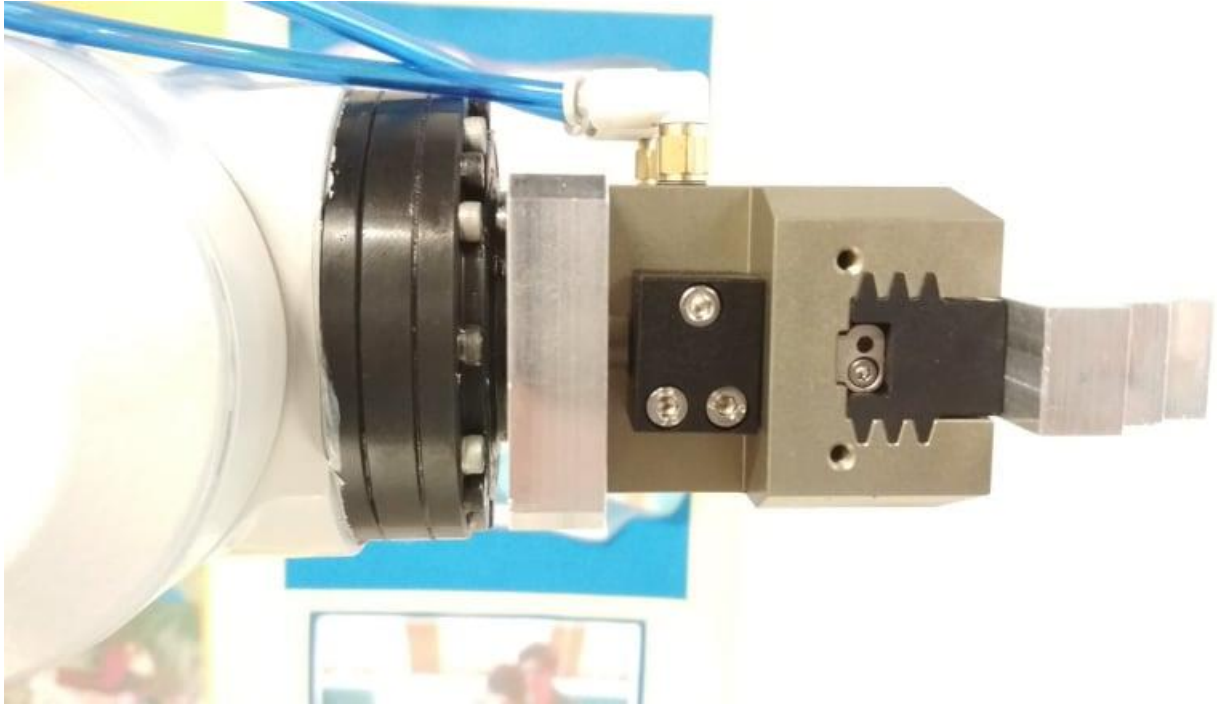

Slika 2.42. Pozicija 0° za 6. os

- Potom potvrdimo pozicije enkodera i postavimo ih kao središte svake osi, to jest u 0° .

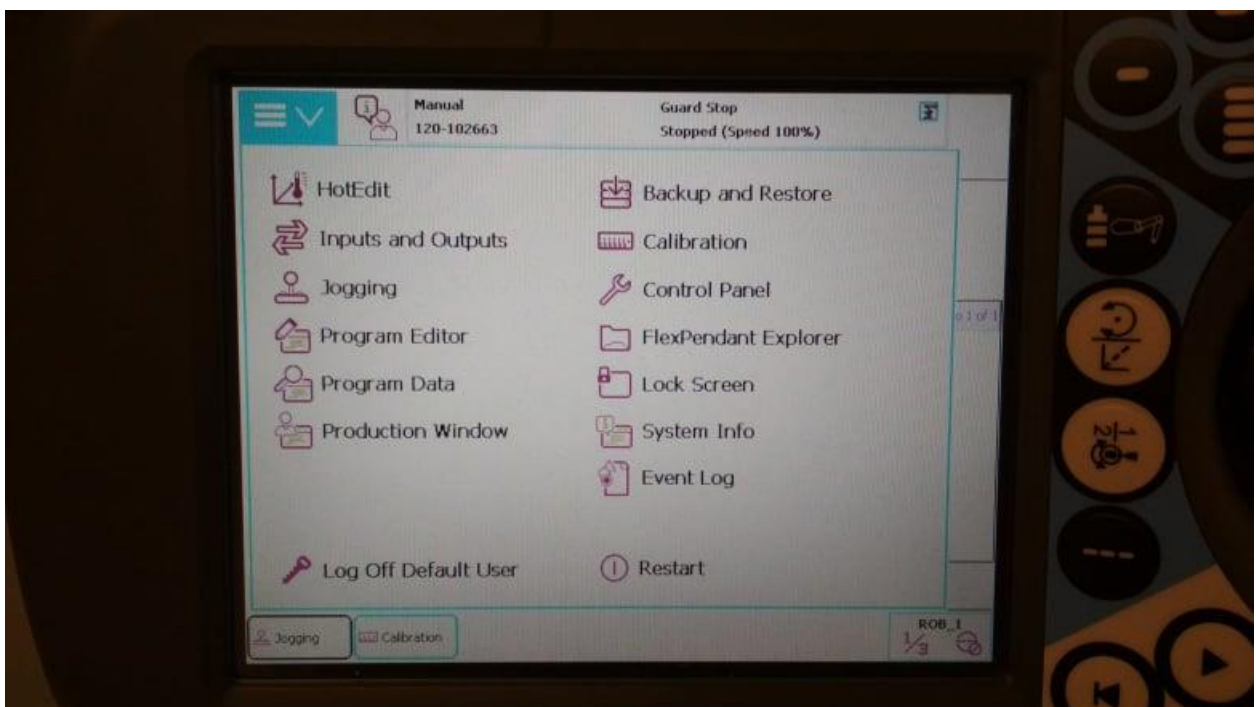

Slika 2.43. 1. korak

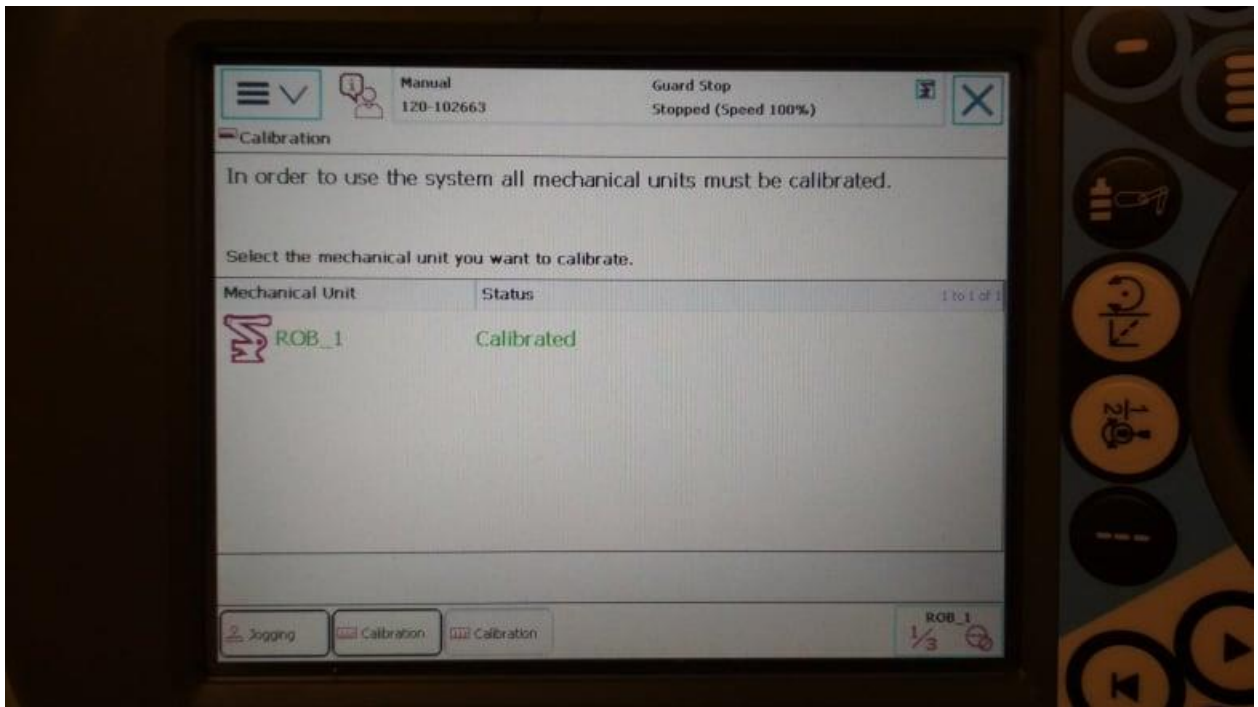

Slika 2.44. 2. korak

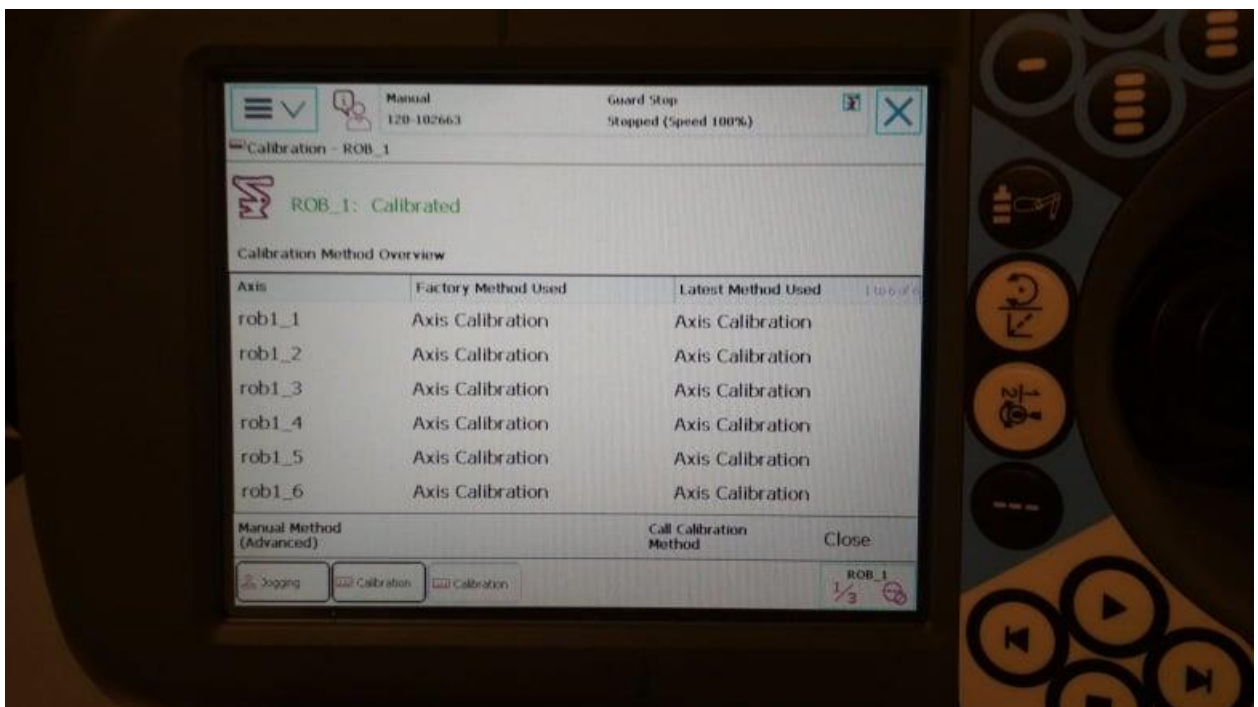

Slika 2.45. 3. korak

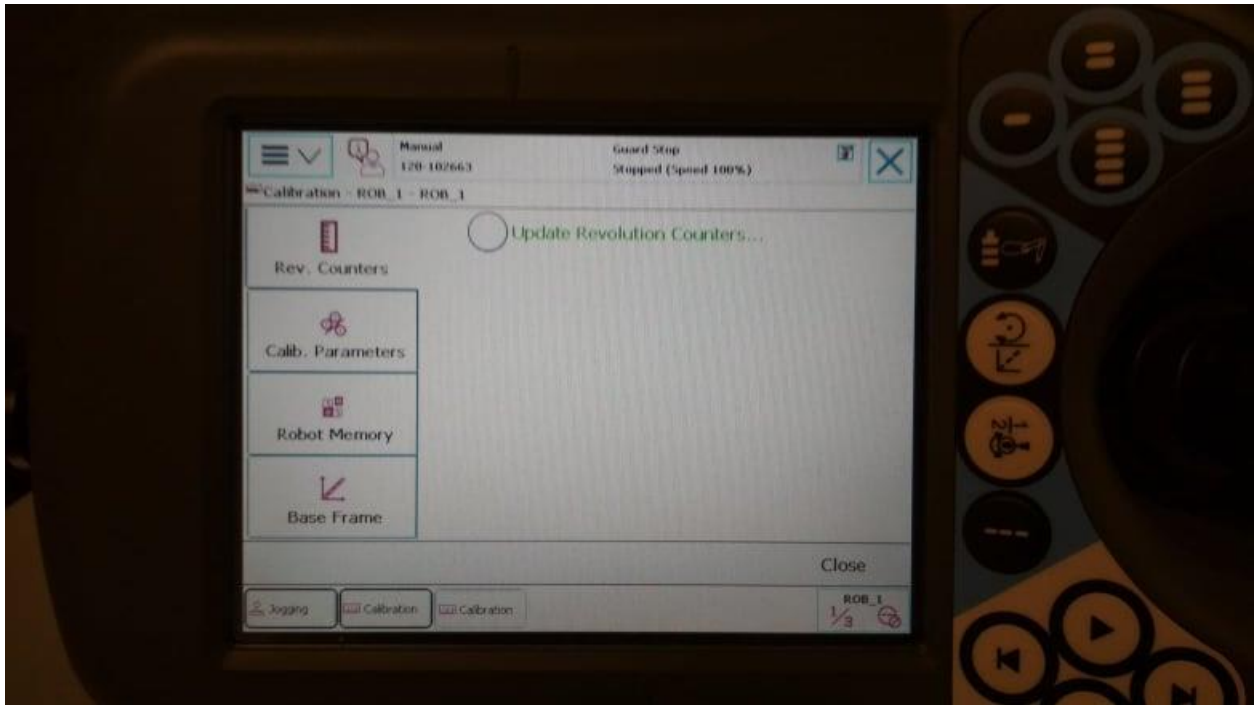

Slika 2.46. 4. korak

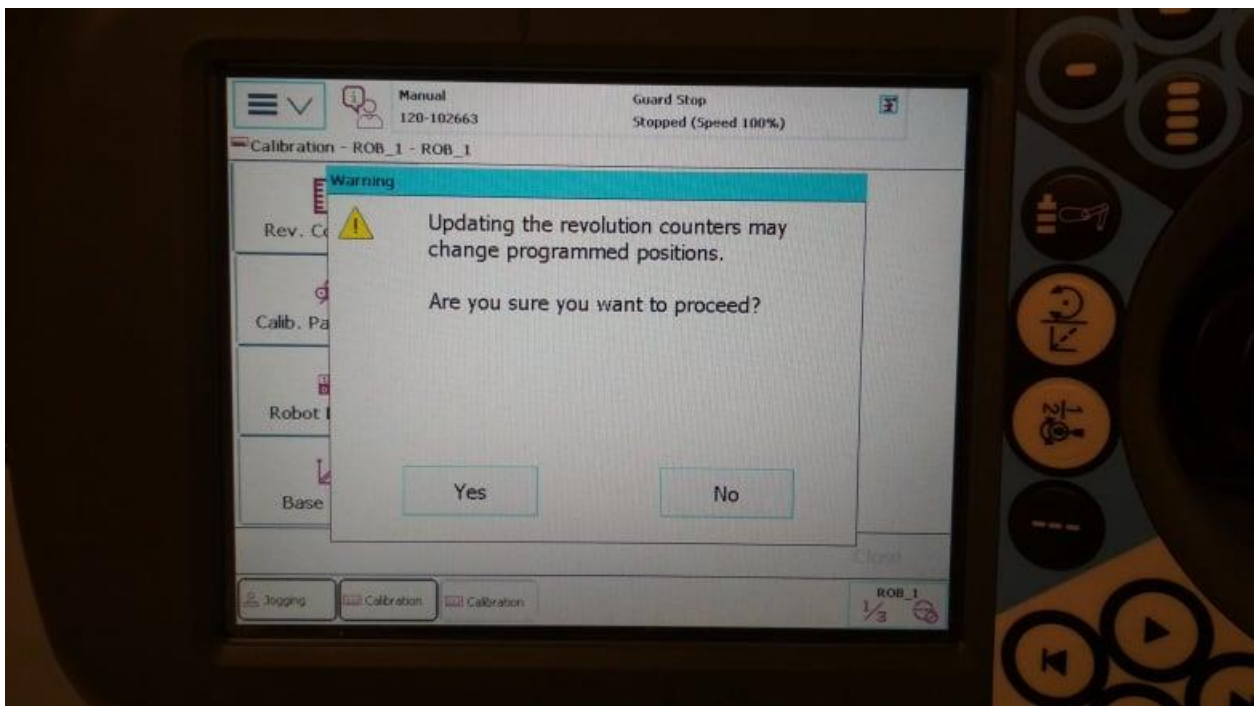

Slika 2.47. 5. korak

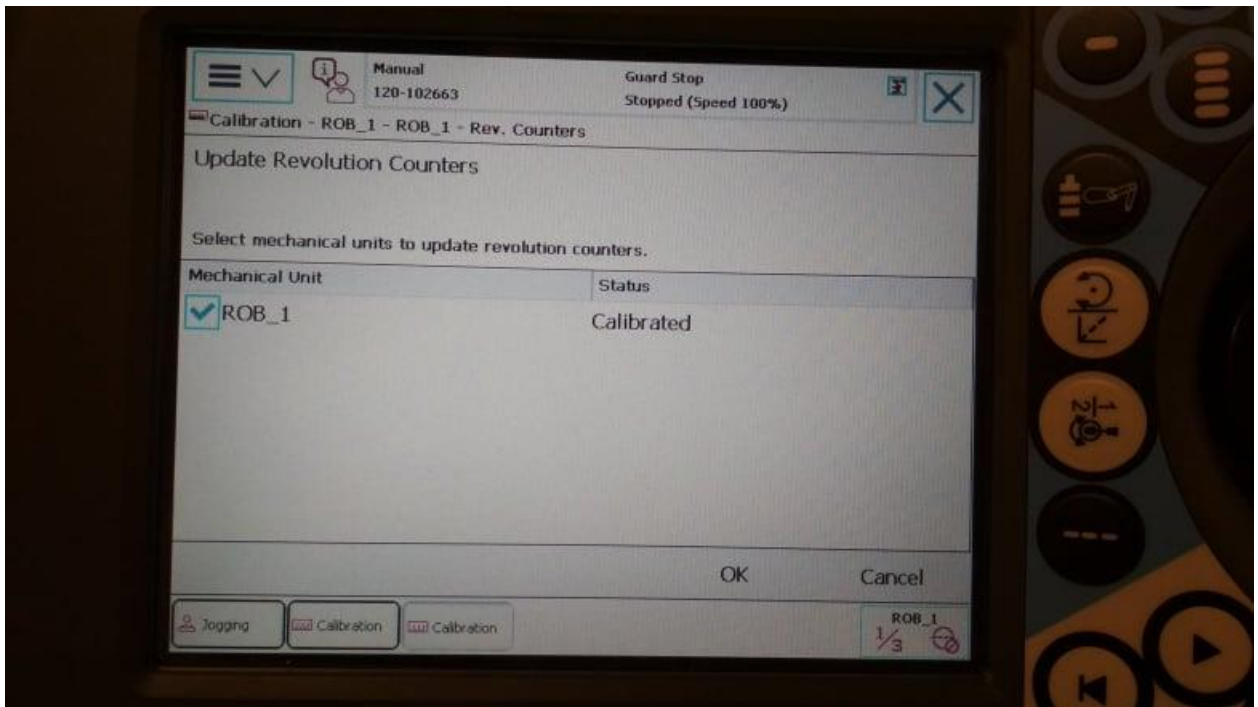

Slika 2.48. 6. korak

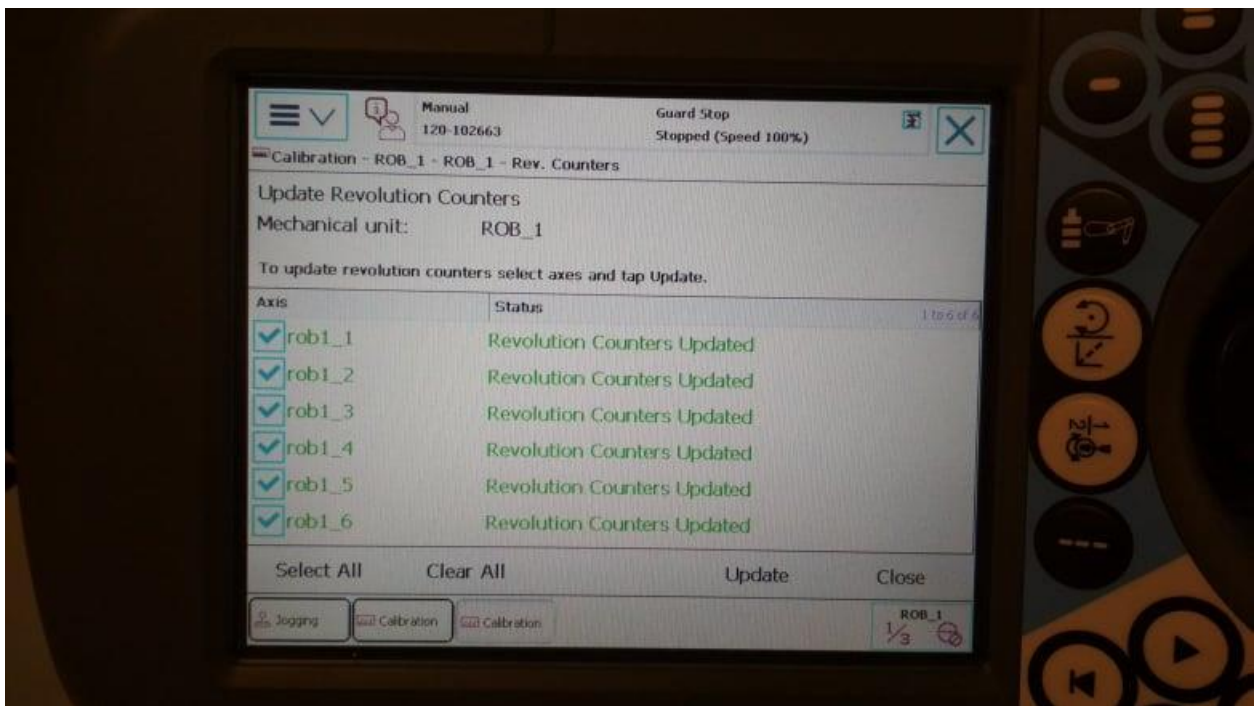

Slika 2.49. 7. korak

3. OSNOVE GLODANJA

3.1. Glodanje

Glodanje je postupak mehaničke obrade materijala odvajanjem krutih čestica rotirajućim alatom, glodalom. Obrada može biti jednostavne ili složene geometrije ovisno o stroju (glodalici) koja se koristi. Glodalice su alatni strojevi kojima se istodobno postiže okretanje glodala i posmak, tj. kontinuirano pomicanje glodala ili površine koja se obrađuje.

Sastoje se od:

- postolja, radnog stola za koji se pričvršćuje predmet koji se obrađuje (obradak)
- glavnog vretena s priključnom glavom glodalice, za koju se pričvršćuje glodalo
- glavnog pogona, kojim se pokreće vreteno

Uglavnom se sastoje od tri osi X,Y,Z, a u novije doba postoje one i s četiri, pet ili više osi. Nekad su se koristile ručne glodalice, a danas se one upravljaju pomoću računala (CNC glodalice). Glodala imaju oštrice (tzv. pera) u obliku zuba koje, kad se glodalo okreće, s obratka skidaju strugotinu sloj po sloj. S obzirom na konstrukciju, razlikuju se glodala s mehanički izrađenim zubima te glodala i glodače glave s umetnutim oštricama. Glodalo se izrađuje od brzoreznog čelika, a rezni dio glodala od materijala znatno veće tvrdoće od obratka (brzorezni čelik, tvrdi metali, keramika, cermet, kubični bor nitrid). Oblici glodala mogu biti različiti: valjkasti, čeoni, vretenasti, pločasti, kutni, profilni i drugi.[10] [11]

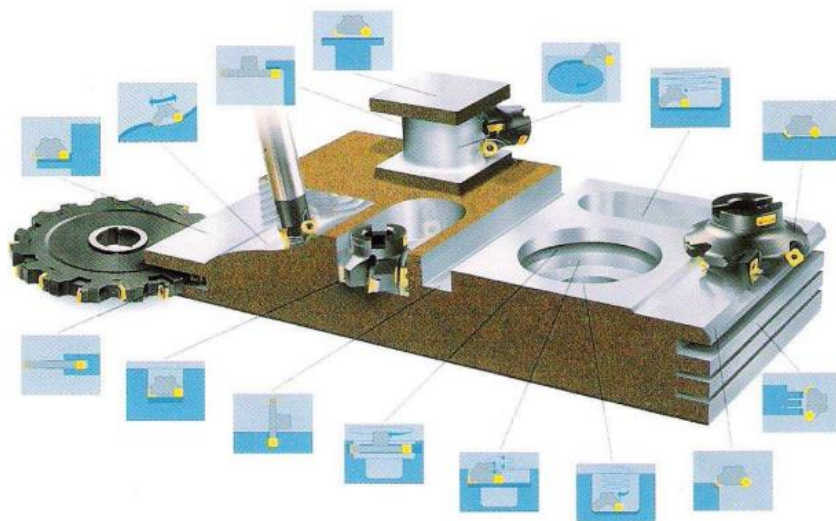

Slika 3.1. Razni oblici glodala [10]

3.2. Gibanje glodala

3.2.1. Koordinatni sustav

U CNC obradi materijala, u ovom slučaju glodanja, središte je označeno slovom W (eng. workpiece zero), a X i Y kao pozitivne osi koordinatnog sustava. Ono je proizvoljno izabrano te ga je moguće mijenjati kako bi se što lakše ubacile konture obratka. U CNC obradi materijala, kao oznaka za dimenzije, koriste se milimetri (mm).

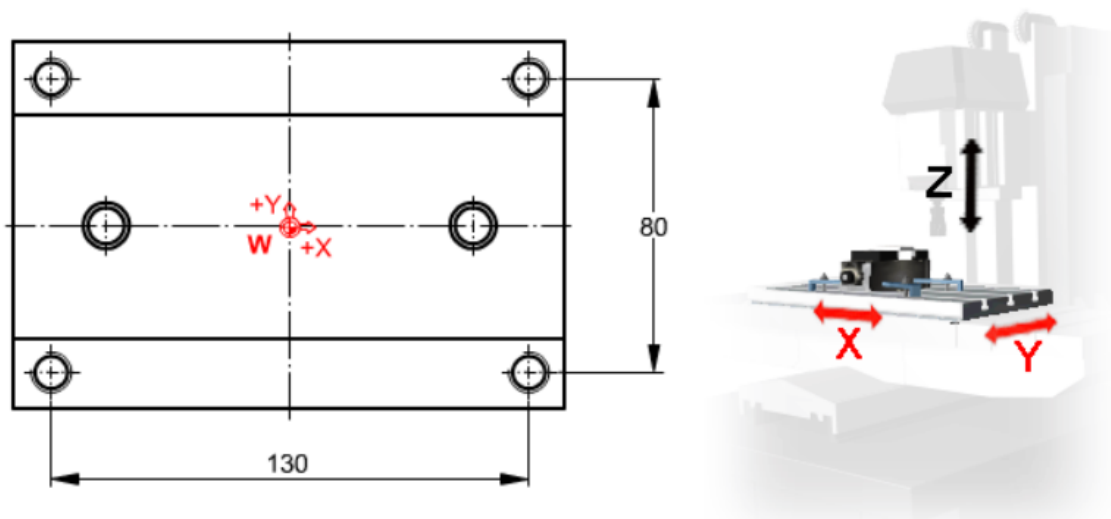

Slika 3.2. Primjer nul-točke obratka

Točke položaja putanje glodala mogu se zadati kao:

- absolutne veličine (s obzirom na središte koordinatnog sustava W)
- inkrementalne veličine (s obzirom na trenutni položaj glodala u koordinatnom sustavu)

3.2.2. Brzina rezanja

U procesu obrade odvajanjem čestica u osnovi postoje dvije manipulativne varijable, a to su brzina i posmak. Brzina određuje koliko se puta glodalo mora okrenuti u jednoj minuti. Brzina n ovisi o brzini rezanja v_c . Brzina se mjeri u okretajima u minuti [okr/min]. Brzina rezanja računa se po formuli: $v_c = d \cdot \pi \cdot n$ [m/min], gdje je d promjer glodala u milimetrima [mm], a n brzina glodala [okr/min]. Brzina rezanja ovisi o mnogo čimbenika kao što su materijal izrade obratka i materijal izrade glodala, odnosno pera glodala. Preporučene vrijednosti brzine rezanja mogu se naći u dokumentaciji proizvođača glodala.

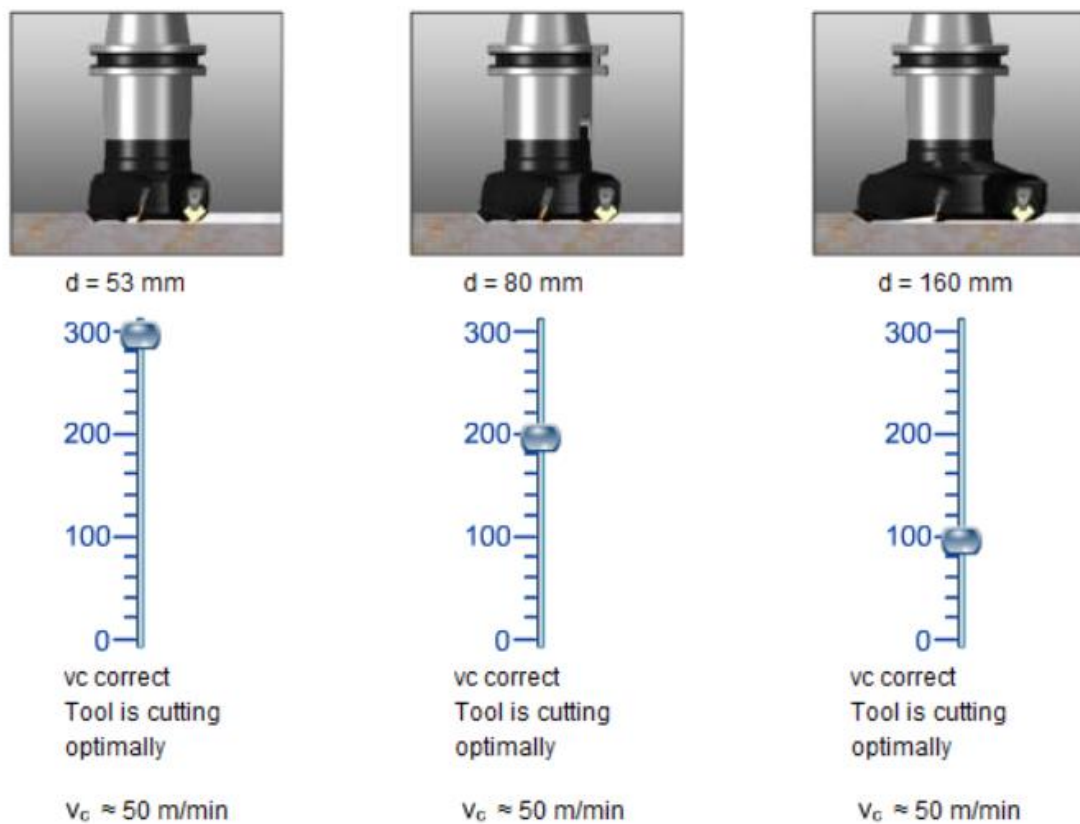

Slika 3.3. Ovisnost brzine rezanja o brzini okretanja glodala

3.2.3. Brzina posmaka

Posmak je još jedna manipulativna varijabla na stroju. On određuje brzinu kojom se glodalo kreće u smjeru obrade obratka. Brzina posmaka v_f ovisi o brzini n i posmaku po rotaciji (ekvivalentno posmak/pero f_z *broj pera z). Posmična brzina se računa prema formuli $v_f = n \cdot f_z \cdot z$ [mm/min]. Glavni faktor u završnoj obradi površine nije nužno posmak već posmak/pero f_z . Ova vrijednost definira udaljenost koju je glodalo obradilo. Varijabla posmak/pero f_z određuje kvalitetu površine. f_z je vrijednost posmak/pero po okretaju. Broj pera izravno utječe na posmak. [12]

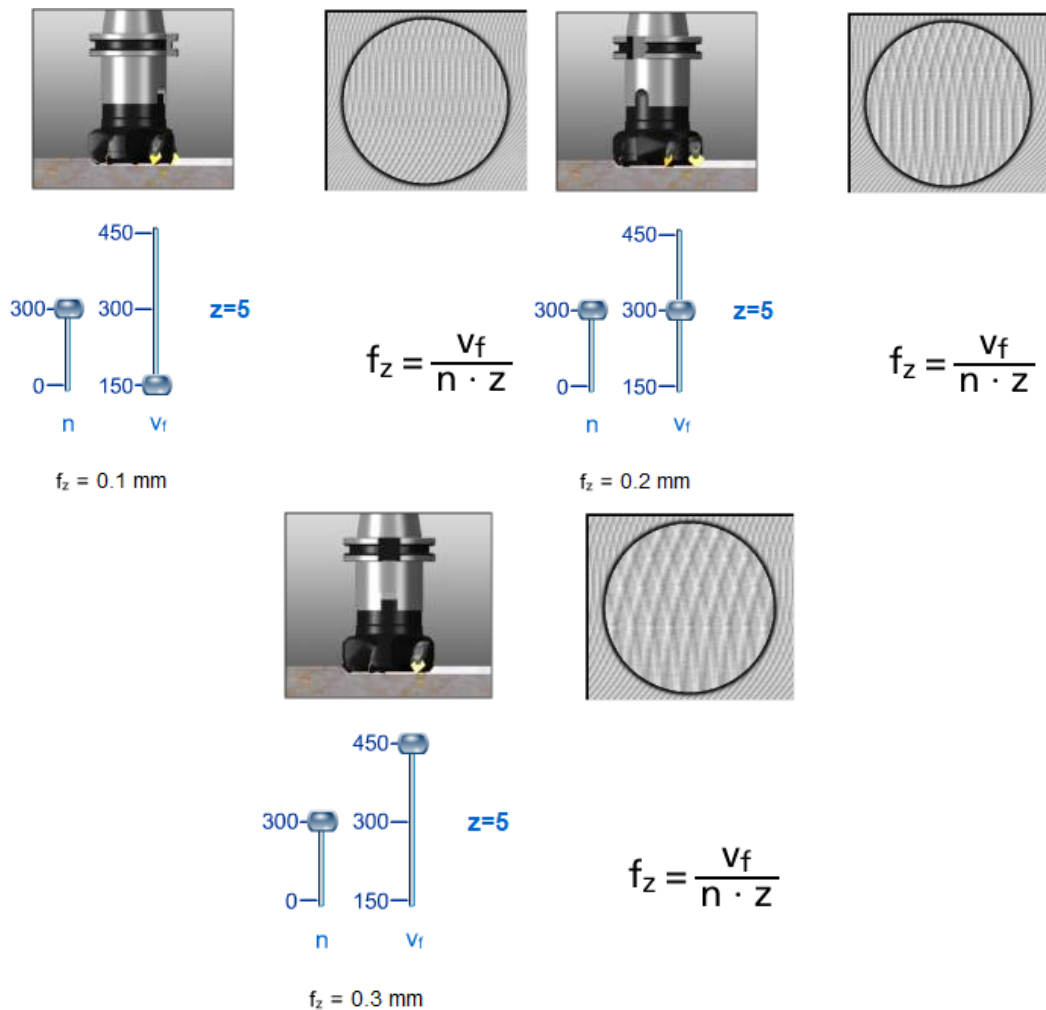

Slika 3.4. Razlika u kvaliteti obrađene površine s obzirom na promjenu posmaka [12]

3.3. G-kod

Kako bi se zadale naredbe računalu, odnosno CNC stroju ili u ovom slučaju industrijskom robotu, potrebno ih je zapisati u kodnom obliku. G-kod ili G funkcija su naredbe u kodnom obliku kojima se zadaje način kretanja alata, odnosno glodala.

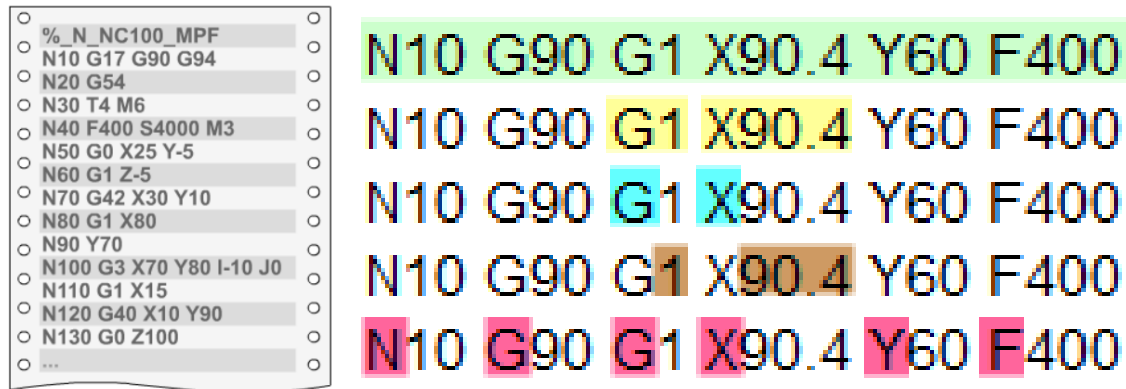

Slika 3.5. Primjer izgleda i programska struktura G-kod-a [12]

3.3.1. Programska struktura

Programska struktura G-kod-a se sastoji od:

- **NC blok**- program izvršava naredbe blok po blok, svaki blok može sadržavati više riječi
- **Riječ**- NC blok sadrži jednu ili više riječi. Na primjer, jedna riječ bi bila „kreći se linearno“, druga „u poziciju 90.4 po X koordinatnoj osi“, a treća „u poziciju 60 po Y koordinatnoj osi“
- **Adrese**- svaka riječ se sastoji od adrese (i iznosa). Svako slovo u adresi ima neko specifično značenje. Na primjer, slovo G se koristi kako bi se zadala komanda geometrije kretanja, a X i Y kao koordinatne osi
- **Iznos**- adresa uvijek dolazi u kombinaciji s nekim iznosom. One predstavljaju ili već preddefiniranu, standardiziranu komandu kao što je G1-kreći se pravocrtno s posmakom, ili je to iznos koji se mijenja, na primjer, koordinate kretanja
- **Format bloka**- kao u „normalnom“ pismu, NC blok mora biti sastavljen prema nekom standardu (DIN 66025 ili ISO 6983). Blok počinje slovom N kao rednim brojem bloka i obično ga slijede slova adrese G, F, S, T, D, M.

3.3.2. Zaglavlje programa

Odabir ravnine-za glodanje, moguće su 3 ravnine. Prve 3, odnosno X,Y i Z, programirane su kao G17 (glodalo se nalazi na Z osi), G18 (glodalo se nalazi na Y osi) i G19 (glodalo se nalazi na X osi).

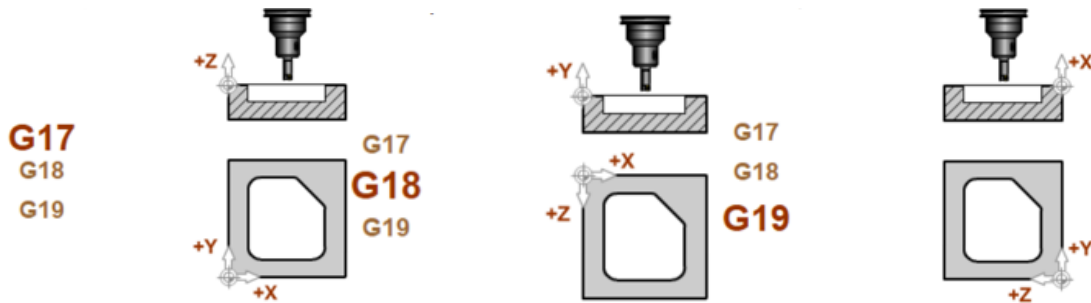

Slika 3.6. Funkcije u skupinama ravnina u kojima se želi raditi [12]

- **Radni „offset“**
 - ukoliko se centar koordinatnog sustava obratka razlikuje od centra koordinatnog sustava glodalice, tada je on definiran s G53 ili G55 + koordinate i odabran s G53.
- **Reference dimenzija**
 - G90-„kreći se do pozicije X ili Y“
 - G91-„kreći se za (neki iznos u milimetrima) po X ili Y“

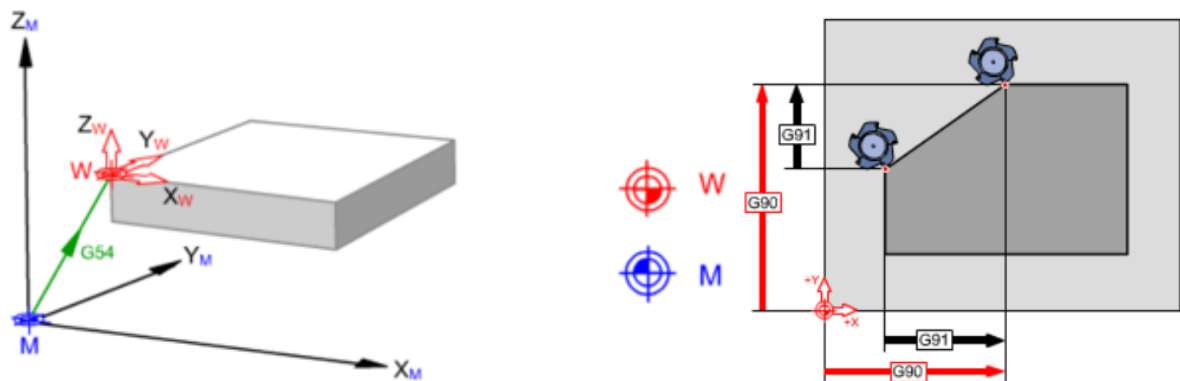

Slika 3.7. Radni „offset“ i reference dimenzija [12]

3.3.3. Adrese F, S, T, D, M

- **F**-posmak glodala
- **S**-brzina [okr/min]
- **T**-glodalo [broj glodala]
- **D**-„offset“ [broj „offseta“]
- **M**-neka modularna adresa koja može biti zadana od proizvođača ili je:
- **M3**-rotacija vretena u smjeru kazaljke na satu
- **M4**-rotacija vretena obrnuto od smjera kazaljke na satu
- **M5**-zaustavljanje vretena
- **M6**-zamjena glodala
- **M8**-paljenje hlađenja

N180 F400 S4000 T4 D1 M3 M6

Slika 3.8. Primjer adresa g-kod-a [12]

3.3.4. Naredbe gibanja G0, G1, G2, G3

- G0-Položaj u brzom kretanju
- G1-Linearna interpolacija s posmakom glodala
- G3-Kružna interpolacija u smjeru kazaljke na satu
- G4-kružna interpolacija u smjeru obrnuto od smjera kazaljke na satu

3.3.5. Kompenzacija putanje alata

- G40-Nema kompenzacije putanje glodala ili poništavanje odabira kompenzacije putanje glodala
- G41-Kompenzacija putanje glodala za kretanje s lijeve strane konture
- G42-Kompenzacija putanje glodala za kretanje s desne strane konture

3.3.6. Informacije o alatu – glodalu

Da bi glodalica „znala“ koje su dimenzije glodala koje se koristi, potrebno je unijeti i te parametre u G-kod. Ovisno o glodalici, industrijskom robotu i programu, odnosno CAM-u, koji koristimo parametri se ondje unose te ih se preko post-procesora generira u G-kod. [13]

3.3.7. Korišteno glavno vreteno u radu

Za potrebe ovog rada korištena je brusilica za graviranje PROXXON FBS 240/E, koja je u ovom završnom radu poslužila kao zamjena za glavno vreteno koje se koristi u industrijskim aplikacijama.



Slika 3.9. Primjer industrijskog glavnog vretena za robotsko glodanje

Neke karakteristike korištene glodalice su:

- maksimalna brzina-22000 [okr/min]
- minimalna brzina 5000 [okr/min]
- konstantan moment na svim brzinama
- ergonomičanost
- robustan dizajn



3.10. Brusilica za graviranje PROXXON FBS 240/E

4. ELEKTROPNEUMATIKA

Pneumatika je tehnička grana koja se bavi izradom pneumatskih uređaja, proučavanjem i iskorištenjem energije stlačenog zraka kao radnog medija uz pomoć mehaničkih uređaja.

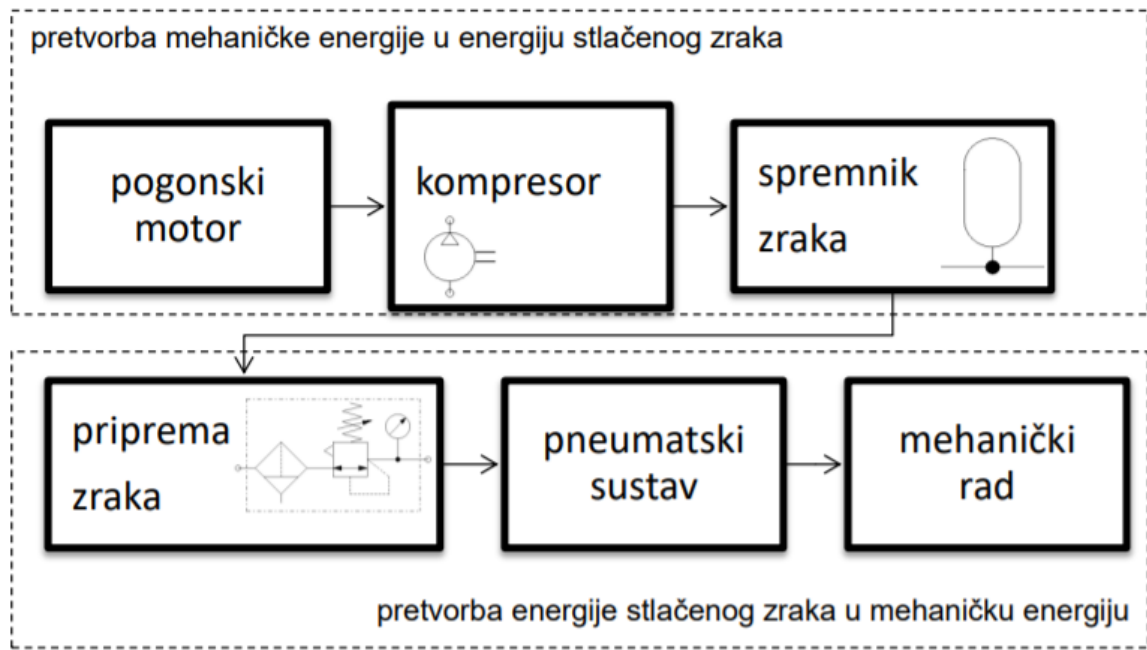

Slika 4.1. Princip rada pneumatskog sustava

Kad se spoje pneumatika i elektronika dobiva se elektropneumatika. Dakle, elektropneumatika je podgrana pneumatike koja je nastala kao hibridni sustav kombinacije pneumatskih i elektroničkih elemenata, tj. komponenti. [14]

4.1. Korišteni kompresor

Kompresor je jedna od osnovnih komponenti kod pneumatike i elektropneumatike. Bez kompresora ne bi bilo stlačenog zraka. U ovom završnom radu koristio se kompresor tvrtke FESTO. FESTO je lider u svijetu za opremanje i automatizaciju industrije pneumatikom i elektropneumatikom. [15]



Slika 4.2. Vijčani kompresor Festo [15]

Glavne karakteristike kompresora su:

- Tlak: 800 kPa (8 bar) Pmax
- Kapacitet usisa: 50 l/min
- Kapacitet spremnika: 24 l
- Promjer ventila izlaza zraka: 1/4"
- Razina buke: 45 dB
- Radni ciklus: maksimalno 50%
- Sadrži regulator tlaka zraka s manometrom

4.2. Korištena pneumatska prihvatnica

Pneumatska prihvatnica SCHUNK PGN-80-1 korištena je u ovom završnom radu kao komponenta na industrijskom robotu ABB IRB 120 za paletizaciju. Nakon što je odrađeno glodanje obratka, pneumatska prihvatnica uzima obrađeni proizvod i premješta ga na željenu poziciju na radnom stolu.



Slika 4.3. Pneumatska prihvatnica SCHUNK PGN-80-1 [16]

4.2.1. Karakteristike korištene prihvatnice

Prihvatnica se sastoji od dvije čeljusti koje se prilikom dobivenog signala, tj. zraka, pomiču lijevo desno, odnosno skupljaju ili otpuštaju ovisno o tome da li želimo prihvatiti ili ispustiti predmet. [16]

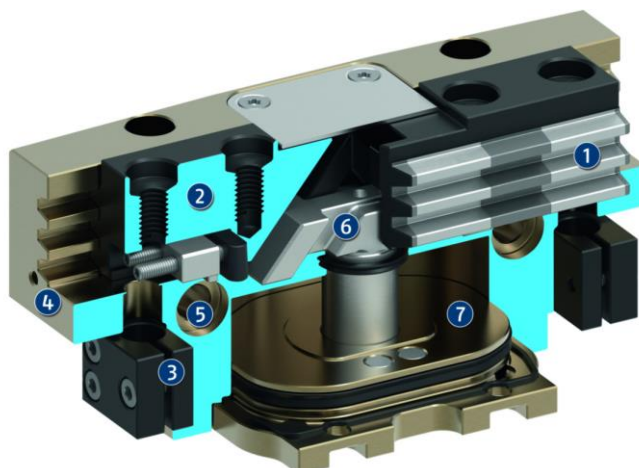

Slika 4.4. Prikaz (presjek) korištene prihvatnice [16]

Glavne karakteristike SCHUNK PGN-80-1 prihvatnice su:

- Hod po čeljusti: 8 mm

- Snaga zatvaranja čeljusti: 550 N
- Snaga otvaranja čeljusti: 610 N
- Maksimalna temperatura okruženja u kojoj prihvatnica može normalno raditi je 90 °C
- Sadrži dva priključka za zrak A i B (ovisno o tome je NO ili NC)

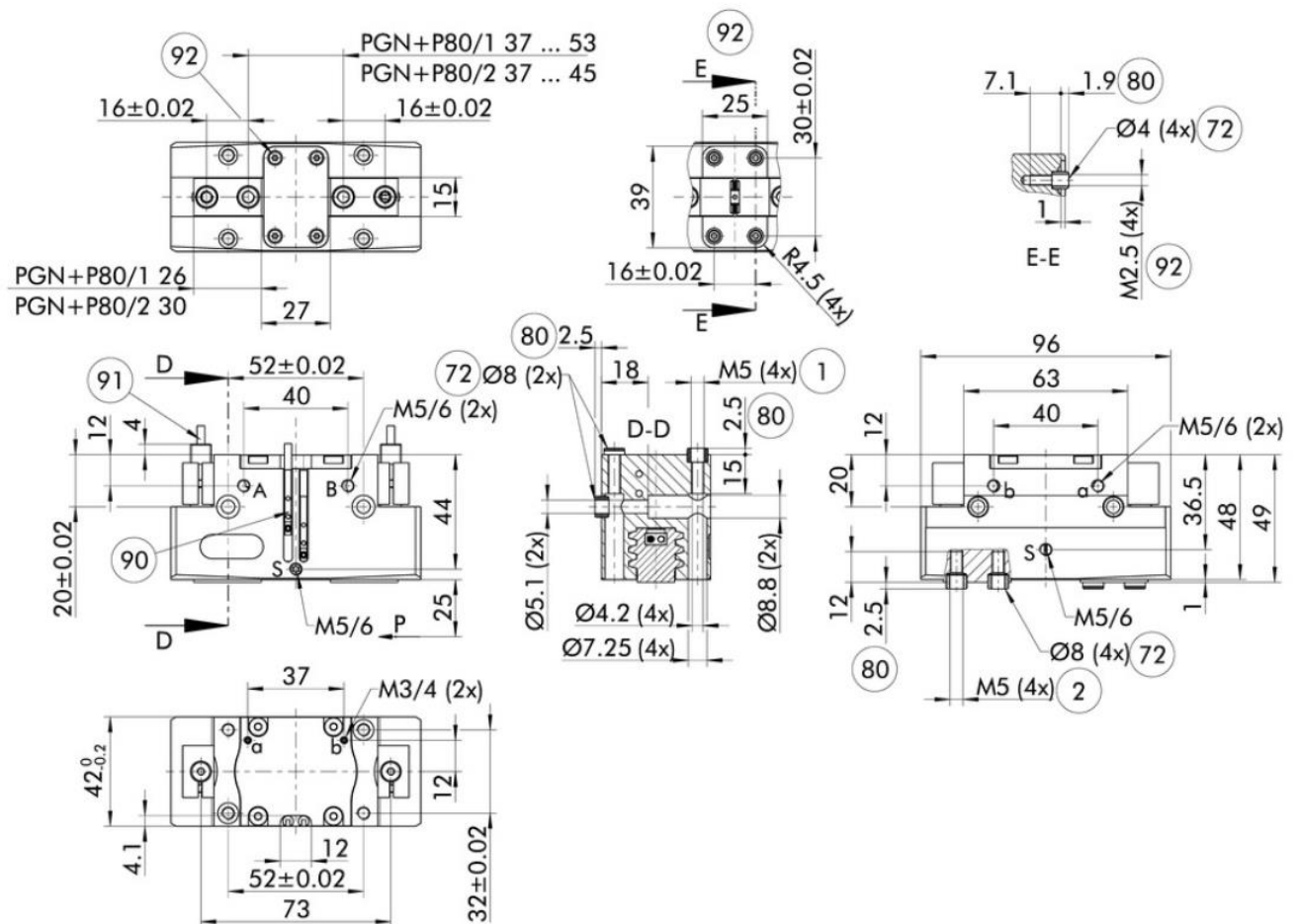

Slika 4.5. Dimenzije prihvatnice s detaljima za montažu [16]

5. REALIZACIJA PROJEKTA GLO DANJA INDUSTRIJSKIM ROBOTOM

Realizacija projekta glodanja industrijskim robotom, odnosno tutorial izrade simulacije u dva djela i video simulacije i glodanja u stvarnom vremenu, može se pogledati na sljedećim linkovima:

1. Izrada simulacije glodanja industrijskim robotom prvi dio; Izrada 3D modela za simulaciju u programu SolidWorks 2017, ubacivanje 3D modela u radni prostor i kreiranje točaka u programu ABB RobotStudio. Dostupno na:
<https://www.youtube.com/watch?v=CHuDS7NYz94>
(27.10.2021.)
2. Izrada simulacije glodanja industrijskim robotom drugi dio; Kreiranje putanji, izrada logike za simulaciju i ulaza/izlaza prihvatnice, te simulacija glodanja u programu ABB RobotStudio. Dostupno na:
<https://www.youtube.com/watch?v=G6Ofp16AcTo>
(27.10.2021.)
3. Prikaz simulacije te video glodanje u stvarnom svijetu i stvarnom vremenu iz dva kuta kamere u labosu na Veleučilištu u Bjelovaru. Dostupno na:
https://www.youtube.com/watch?v=QbserMC_7EY
(27.10.2021.)

6. ZAKLJUČAK

Korištenje industrijskih robota kod obrade odvajanjem čestica (u ovome slučaju glodanja) imati će u budućnosti ogromni udio u proizvodnji. S razvojem pojedinih područja bitnih za ovo područje, industrijski su roboti sve robusniji (govorimo o rotacijskim strukturama sa 6 stupnjeva slobode gibanja). Mogućnosti koje se otvaraju korištenjem istih, u npr. Glodanju, neusporedivo su veće od npr. 5-osnih obradnih centara. Jedina prednost CNC obradnih centara jest krutost, tj. stabilnost u radu.

7. LITERATURA

- [1] Wikipedia, Robotika. Dostupno na:
<https://en.wikipedia.org/wiki/Robotics> (26.10.2021.)
- [2] Balkeshwar Singh , N. Sellappan , Kumaradhas P., IJETAE, Evolution of Industrial Robots and their Applications Volume 3, Issue 5, May 2013, Dostupno na:
https://ijetae.com/files/Volume3Issue5/IJETAE_0513_126.pdf (26.10.2021.)
- [3] PMF,Generacije robota. Dostupno na:
<http://web.studenti.math.pmf.unizg.hr/~btrojko/semrac/generacije%20robota.html> (26.10.2021.)
- [4] Kovačić Z., Bogdan S., Krajči V., Osnove robotike, Graphis, Zagreb, 2001. Dostupno na:
<https://www.scribd.com/document/395768483/Z-Kova%C4%8Di%C4%87-S-Bogdan-V-Kraj%C4%8Di-Osnove-Robotike> (26.10.2021.)
- [5] Velagić J., Laboratorij za Robotiku i autonomne sisteme, Uvod u robotiku. Dostupno na:
http://people.etf.unsa.ba/~jvelagic/laras/dok/Robotika_uvod.pdf (26.10.2021.)
- [6] Web stranica firme ABB. Dostupno na:
<https://global.abb/group/en> (26.10.2021.)
- [7] Katalog specifikacija robota firme ABB. Dostupno na:
<https://search.abb.com/library/Download.aspx?DocumentID=3HAC035960-001&LanguageCode=en&DocumentPartId=&Action=Launch> (26.10.2021.)
- [8] Katalog specifikacija kontrolera firme ABB. Dostupno na:
<https://search.abb.com/library/Download.aspx?DocumentID=ROB0295EN&LanguageCode=en&DocumentPartId=&Action=Launch> (26.10.2021.)
- [9] Katalog specifikacija upravljačke palice firme ABB. Dostupno na:
<https://search.abb.com/library/Download.aspx?DocumentID=ROB0295EN&LanguageCode=en&DocumentPartId=&Action=Launch> (26.10.2021.)
- [10] Glodanje. Hrvatska enciklopedija, mrežno izdanje. Leksikografski zavod Miroslav Krleža, 2021. Dostupno na:
<https://enciklopedija.hr/natuknica.aspx?ID=22345> (26.10.2021.)
- [11] Zavod za tehnologiju, Katedra za alatne strojeve, Škorić S., Glodanje. Dostupno na:
<https://www.fsb.unizg.hr/kas/Tehnologija%20I/Glodanje.pdf> (26.10.2021.)
- [12] Računalni program SINUMERIK, Simens.
- [13] Stranica firme Proxxon. Dostupno na:
<https://www.proxxon.com/hr/> (26.10.2021.)

[14] Maleš N, Visoka tehnička škola u Bjelovaru, Stručni studij mehatronike, Pneumatika i hidraulika, predavanje 6. Dostupno na:

<https://pdfslide.tips/documents/pneumatika-i-hidraulika-6-predavanje-elektropneumatika-55844e2653abe.html> (26.10.2021.)

[15] Katalog specifikacija kompresora firme FESTO. Dostupno na:

<https://www.festo-didactic.com/int-en/learning-systems/equipment-sets/accessories/general/compressor.htm?fbid=aW50LmVuLjU1Ny4xNy4xOC41NTUuMzIxNA>
(26.10.2021.)

[16] Katalog specifikacija prihvatnice firme SCHUNK. Dostupno na:

https://schunk.com/tw_en/gripping-systems/seriesaccessory/pgn-plus-p/product/47850-0318520-pgn-plus-p-80-1 (26.10.2021.)

8. OZNAKE I KRATICE

ABB (eng. Asea Brown Boveri) – ime firme

m – metar (mjerna jedinica)

min – minuta (mjerna jedinica)

mm - milimetar (mjerna jedinica)

N – njutn (mjerna jedinica)

NC – numerical code

PLC programmable logic controller

RRR – rotacijska konfiguracija robota

RRT – sferna konfiguracija robota

RTT – cilindricna konfiguracija robota

TTT – kartezijska ili pravokutna konfiguracija robota

9. SAŽETAK

Naslov: Glodanje industrijskim robotom

U ovom završnom radu opisan je cijeli proces glodanja industrijskim robotom ABB IRB 120. Opisano je podrijetlo riječi i značenje riječi robot i robotika. Nabrojane su prednosti, geometrija radnog prostora, načini upravljanja gibanjem, programiranje i vođenje industrijskih robota. Jasno su strukturirane i pojašnjene osnove o glodanju, te ponešto o elektropneumatici. Navedene su opće značajke robota ABB IRB 120 i alata korištenih za potrebe rada. Detaljno je opisana realizacija projekta glodanja industrijskim robotom u programu ABB Robot studio i Veleučilištu u Bjelovaru.

Ključne riječi: glodanje industrijskim robotom, industrijski roboti, robotika, glodanje, G-kod, ABB, RobotStudio.

10. ABSTRACT

Title: Industrial robotic milling

This final thesis describes the whole process of milling with an industrial robot ABB IRB 120. The origin of the word and the meaning of the word robot and robotics are described. The advantages, workspace geometry, motion control methods, programming and control of industrial robots are listed. The basics of milling, and somewhat of electropneumatics, are clearly structured and clarified. The general characteristics of ABB IRB 120 robots and tools used for work purposes are listed. Detaily described realisation of the whole project for this final thesis of industrial robotic milling in program ABB RobotStudio and at the University of Applied Sciences in Bjelovar.

Keywords: industrial robot milling, industrial robots, robotics, milling, G-code, ABB, RobotStudio.

11. PRILOZI

U ovom poglavlju dodani su sljedeći prilozi koji su korisni za razumijevanje šire slike završnog rada:

- Programski kod

Programski kod

```
MODULE Module1
  CONST robtarget
  Target_10:=[[502.679,94.366,147.5],[0.707106781,0,0.707106781,0],[0,-
1,0,1],[9E+09,9E+09,9E+09,9E+09,9E+09,9E+09]];
  CONST robtarget
  Target_20:=[[492.628,134.366,147.5],[0.707106781,0,0.707106781,0],[0,0,-
1,1],[9E+09,9E+09,9E+09,9E+09,9E+09,9E+09]];
  CONST robtarget
  Target_30:=[[494.173408202,132.5,147.5],[0.707106781,0,0.707106781,0],[0,0,-
1,1],[9E+09,9E+09,9E+09,9E+09,9E+09,9E+09]];
  CONST robtarget
  Target_40:=[[499.921,117.77,147.5],[0.707106781,0,0.707106781,0],[0,-
1,0,1],[9E+09,9E+09,9E+09,9E+09,9E+09,9E+09]];
  CONST robtarget
  Target_50:=[[504.119,101.924,147.5],[0.707106781,0,0.707106781,0],[0,-
1,0,1],[9E+09,9E+09,9E+09,9E+09,9E+09,9E+09]];
  CONST robtarget
  Target_60:=[[515.917,133.594,147.5],[0.707106781,0,0.707106781,0],[0,0,-
1,1],[9E+09,9E+09,9E+09,9E+09,9E+09,9E+09]];
  CONST robtarget
  Target_70:=[[520.473236171,132.5,147.5],[0.707106781,0,0.707106781,0],[0,0,-
1,1],[9E+09,9E+09,9E+09,9E+09,9E+09,9E+09]];
  CONST robtarget
  Target_80:=[[508.276,94.389,147.5],[0.707106781,0,0.707106781,0],[0,0,-
1,1],[9E+09,9E+09,9E+09,9E+09,9E+09,9E+09]];
  CONST robtarget
  V_ULAZ:=[[492.712,132.5,152.5],[0.707106781,0,0.707106781,0],[0,0,-
1,1],[9E+09,9E+09,9E+09,9E+09,9E+09,9E+09]];
  CONST robtarget
  HOME_SCHUNK:=[[523,0,630],[0.707106781,0,0.707106781,0],[0,0,0,1],[9E+09,9E+0
9,9E+09,9E+09,9E+09,9E+09]];
  CONST robtarget
  VUB_1T_HOME_OFFSET:=[[488.899994854,88.999991803,197.499925472],[0.70710675,0
.000000001,0.707106812,-
0.000000009],[0,0,0,1],[9E+09,9E+09,9E+09,9E+09,9E+09,9E+09]];
  CONST robtarget
  V_10:=[[492.712,132.5,142.5],[0.707106781,0,0.707106781,0],[0,0,-
1,1],[9E+09,9E+09,9E+09,9E+09,9E+09,9E+09]];
  CONST robtarget
  V_20:=[[495.634,132.5,142.5],[0.707106781,0,0.707106781,0],[0,0,-
1,1],[9E+09,9E+09,9E+09,9E+09,9E+09,9E+09]];
  CONST robtarget
  V_30:=[[505.141,96.611,142.5],[0.707106781,0,0.707106781,0],[0,0,-
1,1],[9E+09,9E+09,9E+09,9E+09,9E+09,9E+09]];
  CONST robtarget
  V_40:=[[515.225,132.5,142.5],[0.707106781,0,0.707106781,0],[0,0,-
1,1],[9E+09,9E+09,9E+09,9E+09,9E+09,9E+09]];
```

```

CONST robtarget
V_50:=[ [518.132,132.5,142.5], [0.707106781,0,0.707106781,0], [0,0,-
1,1], [9E+09,9E+09,9E+09,9E+09,9E+09,9E+09] ];
CONST robtarget
V_60:=[ [508.189,95.5,142.5], [0.707106781,0,0.707106781,0], [0,0,-
1,1], [9E+09,9E+09,9E+09,9E+09,9E+09,9E+09] ];
CONST robtarget
V_70:=[ [502.009,95.5,142.5], [0.707106781,0,0.707106781,0], [0,0,-
1,1], [9E+09,9E+09,9E+09,9E+09,9E+09,9E+09] ];
CONST robtarget
V_V_10:=[ [494.173,132.5,142.5], [0.707106781,0,0.707106781,0], [0,0,-
1,1], [9E+09,9E+09,9E+09,9E+09,9E+09,9E+09] ];
CONST robtarget
V_V_20:=[ [502.904,98.648,142.5], [0.707106781,0,0.707106781,0], [0,0,-
1,1], [9E+09,9E+09,9E+09,9E+09,9E+09,9E+09] ];
CONST robtarget
V_V_30:=[ [507.728,98.824,142.5], [0.707106781,0,0.707106781,0], [0,0,-
1,1], [9E+09,9E+09,9E+09,9E+09,9E+09,9E+09] ];
CONST robtarget
V_V_40:=[ [516.678,132.5,142.5], [0.707106781,0,0.707106781,0], [0,0,-
1,1], [9E+09,9E+09,9E+09,9E+09,9E+09,9E+09] ];
CONST robtarget
V_IZLAZ:=[ [518.132,132.5,152.5], [0.707106781,0,0.707106781,0], [0,0,-
1,1], [9E+09,9E+09,9E+09,9E+09,9E+09,9E+09] ];
CONST robtarget
V_10_2:=[ [492.712,132.5,137.5], [0.707106781,0,0.707106781,0], [0,0,-
1,1], [9E+09,9E+09,9E+09,9E+09,9E+09,9E+09] ];
CONST robtarget
V_20_2:=[ [495.634,132.5,137.5], [0.707106781,0,0.707106781,0], [0,0,-
1,1], [9E+09,9E+09,9E+09,9E+09,9E+09,9E+09] ];
CONST robtarget
V_30_2:=[ [505.141,96.611,137.5], [0.707106781,0,0.707106781,0], [0,0,-
1,1], [9E+09,9E+09,9E+09,9E+09,9E+09,9E+09] ];
CONST robtarget
V_40_2:=[ [515.225,132.5,137.5], [0.707106781,0,0.707106781,0], [0,0,-
1,1], [9E+09,9E+09,9E+09,9E+09,9E+09,9E+09] ];
CONST robtarget
V_50_2:=[ [518.132,132.5,137.5], [0.707106781,0,0.707106781,0], [0,0,-
1,1], [9E+09,9E+09,9E+09,9E+09,9E+09,9E+09] ];
CONST robtarget
V_60_2:=[ [508.189,95.5,137.5], [0.707106781,0,0.707106781,0], [0,0,-
1,1], [9E+09,9E+09,9E+09,9E+09,9E+09,9E+09] ];
CONST robtarget
V_70_2:=[ [502.009,95.5,137.5], [0.707106781,0,0.707106781,0], [0,0,-
1,1], [9E+09,9E+09,9E+09,9E+09,9E+09,9E+09] ];
CONST robtarget
V_V_10_2:=[ [494.173,132.5,137.5], [0.707106781,0,0.707106781,0], [0,0,-
1,1], [9E+09,9E+09,9E+09,9E+09,9E+09,9E+09] ];
CONST robtarget
V_V_20_2:=[ [502.904,98.648,137.5], [0.707106781,0,0.707106781,0], [0,0,-
1,1], [9E+09,9E+09,9E+09,9E+09,9E+09,9E+09] ];
CONST robtarget
V_V_30_2:=[ [507.728,98.824,137.5], [0.707106781,0,0.707106781,0], [0,0,-
1,1], [9E+09,9E+09,9E+09,9E+09,9E+09,9E+09] ];
CONST robtarget
V_V_40_2:=[ [516.678,132.5,137.5], [0.707106781,0,0.707106781,0], [0,0,-
1,1], [9E+09,9E+09,9E+09,9E+09,9E+09,9E+09] ];
CONST robtarget
U_ULAZ:=[ [528.167,132.5,152.5], [0.707106781,0,0.707106781,0], [0,0,-
1,1], [9E+09,9E+09,9E+09,9E+09,9E+09,9E+09] ];

```

```

CONST robtarget
U_10:=[[528.167,132.5,142.5],[0.707106781,0,0.707106781,0],[0,0,-
1,1],[9E+09,9E+09,9E+09,9E+09,9E+09,9E+09]];
CONST robtarget
U_20:=[[531.167,132.5,142.5],[0.707106781,0,0.707106781,0],[0,0,-
1,1],[9E+09,9E+09,9E+09,9E+09,9E+09,9E+09]];
CONST robtarget
U_30:=[[531.167,106.131,142.5],[0.707106781,0,0.707106781,0],[0,0,-
1,1],[9E+09,9E+09,9E+09,9E+09,9E+09,9E+09]];
CONST robtarget
U_40:=[[532.621,103.497,142.5],[0.707106781,0,0.707106781,0],[0,0,-
1,1],[9E+09,9E+09,9E+09,9E+09,9E+09,9E+09]];
CONST robtarget
U_50:=[[534.841,101.304,142.5],[0.707106781,0,0.707106781,0],[0,0,-
1,1],[9E+09,9E+09,9E+09,9E+09,9E+09,9E+09]];
CONST robtarget
U_60:=[[537.445,99.901,142.5],[0.707106781,0,0.707106781,0],[0,0,-
1,1],[9E+09,9E+09,9E+09,9E+09,9E+09,9E+09]];
CONST robtarget
U_70:=[[540.292,99.268,142.5],[0.707106781,0,0.707106781,0],[0,0,-
1,1],[9E+09,9E+09,9E+09,9E+09,9E+09,9E+09]];
CONST robtarget
U_80:=[[543.195,99.424,142.5],[0.707106781,0,0.707106781,0],[0,0,-
1,1],[9E+09,9E+09,9E+09,9E+09,9E+09,9E+09]];
CONST robtarget
U_90:=[[545.709,100.24,142.5],[0.707106781,0,0.707106781,0],[0,0,-
1,1],[9E+09,9E+09,9E+09,9E+09,9E+09,9E+09]];
CONST robtarget
U_100:=[[548.09,101.767,142.5],[0.707106781,0,0.707106781,0],[0,0,-
1,1],[9E+09,9E+09,9E+09,9E+09,9E+09,9E+09]];
CONST robtarget
U_110:=[[549.872,103.699,142.5],[0.707106781,0,0.707106781,0],[0,0,-
1,1],[9E+09,9E+09,9E+09,9E+09,9E+09,9E+09]];
CONST robtarget
U_120:=[[551.178,106.131,142.5],[0.707106781,0,0.707106781,0],[0,0,-
1,1],[9E+09,9E+09,9E+09,9E+09,9E+09,9E+09]];
CONST robtarget
U_130:=[[551.178,132.5,142.5],[0.707106781,0,0.707106781,0],[0,0,-
1,1],[9E+09,9E+09,9E+09,9E+09,9E+09,9E+09]];
CONST robtarget
U_140:=[[554.178,132.5,142.5],[0.707106781,0,0.707106781,0],[0,0,-
1,1],[9E+09,9E+09,9E+09,9E+09,9E+09,9E+09]];
CONST robtarget
U_150:=[[554.178,104.452,142.5],[0.707106781,0,0.707106781,0],[0,0,-
1,1],[9E+09,9E+09,9E+09,9E+09,9E+09,9E+09]];
CONST robtarget
U_160:=[[553.244,102.33,142.5],[0.707106781,0,0.707106781,0],[0,0,-
1,1],[9E+09,9E+09,9E+09,9E+09,9E+09,9E+09]];
CONST robtarget
U_170:=[[551.891,100.3,142.5],[0.707106781,0,0.707106781,0],[0,0,-
1,1],[9E+09,9E+09,9E+09,9E+09,9E+09,9E+09]];
CONST robtarget
U_180:=[[550.293,98.622,142.5],[0.707106781,0,0.707106781,0],[0,0,-
1,1],[9E+09,9E+09,9E+09,9E+09,9E+09,9E+09]];
CONST robtarget
U_190:=[[548.067,97.015,142.5],[0.707106781,0,0.707106781,0],[0,0,-
1,1],[9E+09,9E+09,9E+09,9E+09,9E+09,9E+09]];
CONST robtarget
U_200:=[[545.902,96,142.5],[0.707106781,0,0.707106781,0],[0,0,-
1,1],[9E+09,9E+09,9E+09,9E+09,9E+09,9E+09]];

```

```

CONST robtarget
U_210:=[ [543.612,95.379,142.5], [0.707106781,0,0.707106781,0], [0,0,-
1,1], [9E+09,9E+09,9E+09,9E+09,9E+09,9E+09]];
CONST robtarget
U_220:=[ [541.549,95.166,142.5], [0.707106781,0,0.707106781,0], [0,0,-
1,1], [9E+09,9E+09,9E+09,9E+09,9E+09,9E+09]];
CONST robtarget
U_230:=[ [539.057,95.325,142.5], [0.707106781,0,0.707106781,0], [0,0,-
1,1], [9E+09,9E+09,9E+09,9E+09,9E+09,9E+09]];
CONST robtarget
U_240:=[ [537.37,95.697,142.5], [0.707106781,0,0.707106781,0], [0,0,-
1,1], [9E+09,9E+09,9E+09,9E+09,9E+09,9E+09]];
CONST robtarget
U_250:=[ [535.612,96.336,142.5], [0.707106781,0,0.707106781,0], [0,0,-
1,1], [9E+09,9E+09,9E+09,9E+09,9E+09,9E+09]];
CONST robtarget
U_260:=[ [533.283,97.65,142.5], [0.707106781,0,0.707106781,0], [0,0,-
1,1], [9E+09,9E+09,9E+09,9E+09,9E+09,9E+09]];
CONST robtarget
U_270:=[ [531.406,99.233,142.5], [0.707106781,0,0.707106781,0], [0,0,-
1,1], [9E+09,9E+09,9E+09,9E+09,9E+09,9E+09]];
CONST robtarget
U_280:=[ [529.489,101.663,142.5], [0.707106781,0,0.707106781,0], [0,0,-
1,1], [9E+09,9E+09,9E+09,9E+09,9E+09,9E+09]];
CONST robtarget
U_290:=[ [528.167,104.452,142.5], [0.707106781,0,0.707106781,0], [0,0,-
1,1], [9E+09,9E+09,9E+09,9E+09,9E+09,9E+09]];
CONST robtarget
U_U_10:=[ [529.667,132.5,142.5], [0.707106781,0,0.707106781,0], [0,0,-
1,1], [9E+09,9E+09,9E+09,9E+09,9E+09,9E+09]];
CONST robtarget
U_U_20:=[ [529.687,105.765,142.5], [0.707106781,0,0.707106781,0], [0,0,-
1,1], [9E+09,9E+09,9E+09,9E+09,9E+09,9E+09]];
CONST robtarget
U_U_30:=[ [530.561,103.239,142.5], [0.707106781,0,0.707106781,0], [0,0,-
1,1], [9E+09,9E+09,9E+09,9E+09,9E+09,9E+09]];
CONST robtarget
U_U_40:=[ [533.087,100.519,142.5], [0.707106781,0,0.707106781,0], [0,0,-
1,1], [9E+09,9E+09,9E+09,9E+09,9E+09,9E+09]];
CONST robtarget
U_U_50:=[ [536.681,98.285,142.5], [0.707106781,0,0.707106781,0], [0,0,-
1,1], [9E+09,9E+09,9E+09,9E+09,9E+09,9E+09]];
CONST robtarget
U_U_60:=[ [540.275,97.313,142.5], [0.707106781,0,0.707106781,0], [0,0,-
1,1], [9E+09,9E+09,9E+09,9E+09,9E+09,9E+09]];
CONST robtarget
U_U_70:=[ [543.675,97.605,142.5], [0.707106781,0,0.707106781,0], [0,0,-
1,1], [9E+09,9E+09,9E+09,9E+09,9E+09,9E+09]];
CONST robtarget
U_U_80:=[ [547.27,99.159,142.5], [0.707106781,0,0.707106781,0], [0,0,-
1,1], [9E+09,9E+09,9E+09,9E+09,9E+09,9E+09]];
CONST robtarget
U_U_90:=[ [549.601,100.811,142.5], [0.707106781,0,0.707106781,0], [0,0,-
1,1], [9E+09,9E+09,9E+09,9E+09,9E+09,9E+09]];
CONST robtarget
U_U_100:=[ [551.35,102.851,142.5], [0.707106781,0,0.707106781,0], [0,0,-
1,1], [9E+09,9E+09,9E+09,9E+09,9E+09,9E+09]];
CONST robtarget
U_U_110:=[ [552.71,105.473,142.5], [0.707106781,0,0.707106781,0], [0,0,-
1,1], [9E+09,9E+09,9E+09,9E+09,9E+09,9E+09]];

```

```

CONST robtarget
U_U_120:=[[552.678,132.5,142.5],[0.707106781,0,0.707106781,0],[0,0,-
1,1],[9E+09,9E+09,9E+09,9E+09,9E+09,9E+09]];
CONST robtarget
U_IZLAZ:=[[554.178,132.5,152.5],[0.707106781,0,0.707106781,0],[0,0,-
1,1],[9E+09,9E+09,9E+09,9E+09,9E+09,9E+09]];
CONST robtarget
U_10_2:=[[528.167,132.5,137.5],[0.707106781,0,0.707106781,0],[0,0,-
1,1],[9E+09,9E+09,9E+09,9E+09,9E+09,9E+09]];
CONST robtarget
U_20_2:=[[531.167,132.5,137.5],[0.707106781,0,0.707106781,0],[0,0,-
1,1],[9E+09,9E+09,9E+09,9E+09,9E+09,9E+09]];
CONST robtarget
U_30_2:=[[531.167,106.131,137.5],[0.707106781,0,0.707106781,0],[0,0,-
1,1],[9E+09,9E+09,9E+09,9E+09,9E+09,9E+09]];
CONST robtarget
U_40_2:=[[532.621,103.497,137.5],[0.707106781,0,0.707106781,0],[0,0,-
1,1],[9E+09,9E+09,9E+09,9E+09,9E+09,9E+09]];
CONST robtarget
U_50_2:=[[534.841,101.304,137.5],[0.707106781,0,0.707106781,0],[0,0,-
1,1],[9E+09,9E+09,9E+09,9E+09,9E+09,9E+09]];
CONST robtarget
U_60_2:=[[537.445,99.901,137.5],[0.707106781,0,0.707106781,0],[0,0,-
1,1],[9E+09,9E+09,9E+09,9E+09,9E+09,9E+09]];
CONST robtarget
U_70_2:=[[540.292,99.268,137.5],[0.707106781,0,0.707106781,0],[0,0,-
1,1],[9E+09,9E+09,9E+09,9E+09,9E+09,9E+09]];
CONST robtarget
U_80_2:=[[543.195,99.424,137.5],[0.707106781,0,0.707106781,0],[0,0,-
1,1],[9E+09,9E+09,9E+09,9E+09,9E+09,9E+09]];
CONST robtarget
U_90_2:=[[545.709,100.24,137.5],[0.707106781,0,0.707106781,0],[0,0,-
1,1],[9E+09,9E+09,9E+09,9E+09,9E+09,9E+09]];
CONST robtarget
U_100_2:=[[548.09,101.767,137.5],[0.707106781,0,0.707106781,0],[0,0,-
1,1],[9E+09,9E+09,9E+09,9E+09,9E+09,9E+09]];
CONST robtarget
U_110_2:=[[549.872,103.699,137.5],[0.707106781,0,0.707106781,0],[0,0,-
1,1],[9E+09,9E+09,9E+09,9E+09,9E+09,9E+09]];
CONST robtarget
U_120_2:=[[551.178,106.131,137.5],[0.707106781,0,0.707106781,0],[0,0,-
1,1],[9E+09,9E+09,9E+09,9E+09,9E+09,9E+09]];
CONST robtarget
U_130_2:=[[551.178,132.5,137.5],[0.707106781,0,0.707106781,0],[0,0,-
1,1],[9E+09,9E+09,9E+09,9E+09,9E+09,9E+09]];
CONST robtarget
U_140_2:=[[554.178,132.5,137.5],[0.707106781,0,0.707106781,0],[0,0,-
1,1],[9E+09,9E+09,9E+09,9E+09,9E+09,9E+09]];
CONST robtarget
U_150_2:=[[554.178,104.452,137.5],[0.707106781,0,0.707106781,0],[0,0,-
1,1],[9E+09,9E+09,9E+09,9E+09,9E+09,9E+09]];
CONST robtarget
U_160_2:=[[553.244,102.33,137.5],[0.707106781,0,0.707106781,0],[0,0,-
1,1],[9E+09,9E+09,9E+09,9E+09,9E+09,9E+09]];
CONST robtarget
U_170_2:=[[551.891,100.3,137.5],[0.707106781,0,0.707106781,0],[0,0,-
1,1],[9E+09,9E+09,9E+09,9E+09,9E+09,9E+09]];
CONST robtarget
U_180_2:=[[550.293,98.622,137.5],[0.707106781,0,0.707106781,0],[0,0,-
1,1],[9E+09,9E+09,9E+09,9E+09,9E+09,9E+09]];

```

```

CONST robtarget
U_190_2:=[ [548.067,97.015,137.5], [0.707106781,0,0.707106781,0], [0,0,-
1,1], [9E+09,9E+09,9E+09,9E+09,9E+09,9E+09]];
CONST robtarget
U_200_2:=[ [545.902,96,137.5], [0.707106781,0,0.707106781,0], [0,0,-
1,1], [9E+09,9E+09,9E+09,9E+09,9E+09,9E+09]];
CONST robtarget
U_210_2:=[ [543.612,95.379,137.5], [0.707106781,0,0.707106781,0], [0,0,-
1,1], [9E+09,9E+09,9E+09,9E+09,9E+09,9E+09]];
CONST robtarget
U_220_2:=[ [541.549,95.166,137.5], [0.707106781,0,0.707106781,0], [0,0,-
1,1], [9E+09,9E+09,9E+09,9E+09,9E+09,9E+09]];
CONST robtarget
U_230_2:=[ [539.057,95.325,137.5], [0.707106781,0,0.707106781,0], [0,0,-
1,1], [9E+09,9E+09,9E+09,9E+09,9E+09,9E+09]];
CONST robtarget
U_240_2:=[ [537.37,95.697,137.5], [0.707106781,0,0.707106781,0], [0,0,-
1,1], [9E+09,9E+09,9E+09,9E+09,9E+09,9E+09]];
CONST robtarget
U_250_2:=[ [535.612,96.336,137.5], [0.707106781,0,0.707106781,0], [0,0,-
1,1], [9E+09,9E+09,9E+09,9E+09,9E+09,9E+09]];
CONST robtarget
U_260_2:=[ [533.283,97.65,137.5], [0.707106781,0,0.707106781,0], [0,0,-
1,1], [9E+09,9E+09,9E+09,9E+09,9E+09,9E+09]];
CONST robtarget
U_270_2:=[ [531.406,99.233,137.5], [0.707106781,0,0.707106781,0], [0,0,-
1,1], [9E+09,9E+09,9E+09,9E+09,9E+09,9E+09]];
CONST robtarget
U_280_2:=[ [529.489,101.663,137.5], [0.707106781,0,0.707106781,0], [0,0,-
1,1], [9E+09,9E+09,9E+09,9E+09,9E+09,9E+09]];
CONST robtarget
U_290_2:=[ [528.167,104.452,137.5], [0.707106781,0,0.707106781,0], [0,0,-
1,1], [9E+09,9E+09,9E+09,9E+09,9E+09,9E+09]];
CONST robtarget
U_U_10_2:=[ [529.667,132.5,137.5], [0.707106781,0,0.707106781,0], [0,0,-
1,1], [9E+09,9E+09,9E+09,9E+09,9E+09,9E+09]];
CONST robtarget
U_U_20_2:=[ [529.687,105.765,137.5], [0.707106781,0,0.707106781,0], [0,0,-
1,1], [9E+09,9E+09,9E+09,9E+09,9E+09,9E+09]];
CONST robtarget
U_U_30_2:=[ [530.561,103.239,137.5], [0.707106781,0,0.707106781,0], [0,0,-
1,1], [9E+09,9E+09,9E+09,9E+09,9E+09,9E+09]];
CONST robtarget
U_U_40_2:=[ [533.087,100.519,137.5], [0.707106781,0,0.707106781,0], [0,0,-
1,1], [9E+09,9E+09,9E+09,9E+09,9E+09,9E+09]];
CONST robtarget
U_U_50_2:=[ [536.681,98.285,137.5], [0.707106781,0,0.707106781,0], [0,0,-
1,1], [9E+09,9E+09,9E+09,9E+09,9E+09,9E+09]];
CONST robtarget
U_U_60_2:=[ [540.275,97.313,137.5], [0.707106781,0,0.707106781,0], [0,0,-
1,1], [9E+09,9E+09,9E+09,9E+09,9E+09,9E+09]];
CONST robtarget
U_U_70_2:=[ [543.675,97.605,137.5], [0.707106781,0,0.707106781,0], [0,0,-
1,1], [9E+09,9E+09,9E+09,9E+09,9E+09,9E+09]];
CONST robtarget
U_U_80_2:=[ [547.27,99.159,137.5], [0.707106781,0,0.707106781,0], [0,0,-
1,1], [9E+09,9E+09,9E+09,9E+09,9E+09,9E+09]];
CONST robtarget
U_U_90_2:=[ [549.601,100.811,137.5], [0.707106781,0,0.707106781,0], [0,0,-
1,1], [9E+09,9E+09,9E+09,9E+09,9E+09,9E+09]];

```

```

CONST robtarget
U_U_100_2:=[[551.35,102.851,137.5],[0.707106781,0,0.707106781,0],[0,0,-
1,1],[9E+09,9E+09,9E+09,9E+09,9E+09,9E+09]];
CONST robtarget
U_U_110_2:=[[552.71,105.473,137.5],[0.707106781,0,0.707106781,0],[0,0,-
1,1],[9E+09,9E+09,9E+09,9E+09,9E+09,9E+09]];
CONST robtarget
U_U_120_2:=[[552.678,132.5,137.5],[0.707106781,0,0.707106781,0],[0,0,-
1,1],[9E+09,9E+09,9E+09,9E+09,9E+09,9E+09]];
CONST robtarget
B_ULAZ:=[[563.593,132.5,152.5],[0.707106781,0,0.707106781,0],[0,0,-
1,1],[9E+09,9E+09,9E+09,9E+09,9E+09,9E+09]];
CONST robtarget
B_10:=[[563.593,132.5,142.5],[0.707106781,0,0.707106781,0],[0,0,-
1,1],[9E+09,9E+09,9E+09,9E+09,9E+09,9E+09]];
CONST robtarget
B_20:=[[576.238,132.5,142.5],[0.707106781,0,0.707106781,0],[0,0,-
1,1],[9E+09,9E+09,9E+09,9E+09,9E+09,9E+09]];
CONST robtarget
B_30:=[[579.539,131.231,142.5],[0.707106781,0,0.707106781,0],[0,0,-
1,1],[9E+09,9E+09,9E+09,9E+09,9E+09,9E+09]];
CONST robtarget
B_40:=[[582.15,128.69,142.5],[0.707106781,0,0.707106781,0],[0,0,-
1,1],[9E+09,9E+09,9E+09,9E+09,9E+09,9E+09]];
CONST robtarget
B_50:=[[583.542,125.249,142.5],[0.707106781,0,0.707106781,0],[0,0,-
1,1],[9E+09,9E+09,9E+09,9E+09,9E+09,9E+09]];
CONST robtarget
B_60:=[[583.411,121.525,142.5],[0.707106781,0,0.707106781,0],[0,0,-
1,1],[9E+09,9E+09,9E+09,9E+09,9E+09,9E+09]];
CONST robtarget
B_70:=[[581.642,118.017,142.5],[0.707106781,0,0.707106781,0],[0,0,-
1,1],[9E+09,9E+09,9E+09,9E+09,9E+09,9E+09]];
CONST robtarget
B_80:=[[579.528,116.15,142.5],[0.707106781,0,0.707106781,0],[0,0,-
1,1],[9E+09,9E+09,9E+09,9E+09,9E+09,9E+09]];
CONST robtarget
B_90:=[[576.133,114.928,142.5],[0.707106781,0,0.707106781,0],[0,0,-
1,1],[9E+09,9E+09,9E+09,9E+09,9E+09,9E+09]];
CONST robtarget
B_100:=[[579.463,114.269,142.5],[0.707106781,0,0.707106781,0],[0,0,-
1,1],[9E+09,9E+09,9E+09,9E+09,9E+09,9E+09]];
CONST robtarget
B_110:=[[581.865,112.916,142.5],[0.707106781,0,0.707106781,0],[0,0,-
1,1],[9E+09,9E+09,9E+09,9E+09,9E+09,9E+09]];
CONST robtarget
B_120:=[[584.072,110.536,142.5],[0.707106781,0,0.707106781,0],[0,0,-
1,1],[9E+09,9E+09,9E+09,9E+09,9E+09,9E+09]];
CONST robtarget
B_130:=[[585.458,107.182,142.5],[0.707106781,0,0.707106781,0],[0,0,-
1,1],[9E+09,9E+09,9E+09,9E+09,9E+09,9E+09]];
CONST robtarget
B_140:=[[585.537,103.67,142.5],[0.707106781,0,0.707106781,0],[0,0,-
1,1],[9E+09,9E+09,9E+09,9E+09,9E+09,9E+09]];
CONST robtarget
B_150:=[[583.935,99.684,142.5],[0.707106781,0,0.707106781,0],[0,0,-
1,1],[9E+09,9E+09,9E+09,9E+09,9E+09,9E+09]];
CONST robtarget
B_160:=[[581.876,97.515,142.5],[0.707106781,0,0.707106781,0],[0,0,-
1,1],[9E+09,9E+09,9E+09,9E+09,9E+09,9E+09]];

```

```

CONST robtarget
B_170:=[ [578.925,95.962,142.5], [0.707106781,0,0.707106781,0], [0,0,-
1,1], [9E+09,9E+09,9E+09,9E+09,9E+09,9E+09]];
CONST robtarget
B_180:=[ [577.248,95.58,142.5], [0.707106781,0,0.707106781,0], [0,0,-
1,1], [9E+09,9E+09,9E+09,9E+09,9E+09,9E+09]];
CONST robtarget
B_190:=[ [574.328,95.627,142.5], [0.707106781,0,0.707106781,0], [0,0,-
1,1], [9E+09,9E+09,9E+09,9E+09,9E+09,9E+09]];
CONST robtarget
B_200:=[ [572.122,95.5,142.5], [0.707106781,0,0.707106781,0], [0,0,-
1,1], [9E+09,9E+09,9E+09,9E+09,9E+09,9E+09]];
CONST robtarget
B_210:=[ [569.351,95.5,142.5], [0.707106781,0,0.707106781,0], [0,0,-
1,1], [9E+09,9E+09,9E+09,9E+09,9E+09,9E+09]];
CONST robtarget
B_220:=[ [567.058,95.5,142.5], [0.707106781,0,0.707106781,0], [0,0,-
1,1], [9E+09,9E+09,9E+09,9E+09,9E+09,9E+09]];
CONST robtarget
B_230:=[ [563.593,95.5,142.5], [0.707106781,0,0.707106781,0], [0,0,-
1,1], [9E+09,9E+09,9E+09,9E+09,9E+09,9E+09]];
CONST robtarget
B_240:=[ [567.513,129.147,142.5], [0.707106781,0,0.707106781,0], [0,0,-
1,1], [9E+09,9E+09,9E+09,9E+09,9E+09,9E+09]];
CONST robtarget
B_250:=[ [573.46,129.147,142.5], [0.707106781,0,0.707106781,0], [0,0,-
1,1], [9E+09,9E+09,9E+09,9E+09,9E+09,9E+09]];
CONST robtarget
B_260:=[ [577.023,128.133,142.5], [0.707106781,0,0.707106781,0], [0,0,-
1,1], [9E+09,9E+09,9E+09,9E+09,9E+09,9E+09]];
CONST robtarget
B_270:=[ [578.848,126.474,142.5], [0.707106781,0,0.707106781,0], [0,0,-
1,1], [9E+09,9E+09,9E+09,9E+09,9E+09,9E+09]];
CONST robtarget
B_280:=[ [580.14,123.465,142.5], [0.707106781,0,0.707106781,0], [0,0,-
1,1], [9E+09,9E+09,9E+09,9E+09,9E+09,9E+09]];
CONST robtarget
B_290:=[ [579.855,120.162,142.5], [0.707106781,0,0.707106781,0], [0,0,-
1,1], [9E+09,9E+09,9E+09,9E+09,9E+09,9E+09]];
CONST robtarget
B_300:=[ [578.564,117.933,142.5], [0.707106781,0,0.707106781,0], [0,0,-
1,1], [9E+09,9E+09,9E+09,9E+09,9E+09,9E+09]];
CONST robtarget
B_310:=[ [575.984,116.098,142.5], [0.707106781,0,0.707106781,0], [0,0,-
1,1], [9E+09,9E+09,9E+09,9E+09,9E+09,9E+09]];
CONST robtarget
B_320:=[ [573.842,115.62,142.5], [0.707106781,0,0.707106781,0], [0,0,-
1,1], [9E+09,9E+09,9E+09,9E+09,9E+09,9E+09]];
CONST robtarget
B_330:=[ [571.485,115.379,142.5], [0.707106781,0,0.707106781,0], [0,0,-
1,1], [9E+09,9E+09,9E+09,9E+09,9E+09,9E+09]];
CONST robtarget
B_340:=[ [569.053,115.609,142.5], [0.707106781,0,0.707106781,0], [0,0,-
1,1], [9E+09,9E+09,9E+09,9E+09,9E+09,9E+09]];
CONST robtarget
B_350:=[ [567.513,115.609,142.5], [0.707106781,0,0.707106781,0], [0,0,-
1,1], [9E+09,9E+09,9E+09,9E+09,9E+09,9E+09]];
CONST robtarget
B_360:=[ [567.513,112.809,142.5], [0.707106781,0,0.707106781,0], [0,0,-
1,1], [9E+09,9E+09,9E+09,9E+09,9E+09,9E+09]];

```



```

CONST robtarget
B_370:=[ [573.366,112.809,142.5], [0.707106781,0,0.707106781,0], [0,0,-
1,1], [9E+09,9E+09,9E+09,9E+09,9E+09,9E+09]];
CONST robtarget
B_380:=[ [577.453,112.068,142.5], [0.707106781,0,0.707106781,0], [0,0,-
1,1], [9E+09,9E+09,9E+09,9E+09,9E+09,9E+09]];
CONST robtarget
B_390:=[ [580.199,109.555,142.5], [0.707106781,0,0.707106781,0], [0,0,-
1,1], [9E+09,9E+09,9E+09,9E+09,9E+09,9E+09]];
CONST robtarget
B_400:=[ [581.299,106.007,142.5], [0.707106781,0,0.707106781,0], [0,0,-
1,1], [9E+09,9E+09,9E+09,9E+09,9E+09,9E+09]];
CONST robtarget
B_410:=[ [580.526,102.518,142.5], [0.707106781,0,0.707106781,0], [0,0,-
1,1], [9E+09,9E+09,9E+09,9E+09,9E+09,9E+09]];
CONST robtarget
B_420:=[ [578.583,100.158,142.5], [0.707106781,0,0.707106781,0], [0,0,-
1,1], [9E+09,9E+09,9E+09,9E+09,9E+09,9E+09]];
CONST robtarget
B_430:=[ [576.639,99.076,142.5], [0.707106781,0,0.707106781,0], [0,0,-
1,1], [9E+09,9E+09,9E+09,9E+09,9E+09,9E+09]];
CONST robtarget
B_440:=[ [574.052,98.645,142.5], [0.707106781,0,0.707106781,0], [0,0,-
1,1], [9E+09,9E+09,9E+09,9E+09,9E+09,9E+09]];
CONST robtarget
B_450:=[ [571.296,98.692,142.5], [0.707106781,0,0.707106781,0], [0,0,-
1,1], [9E+09,9E+09,9E+09,9E+09,9E+09,9E+09]];
CONST robtarget
B_460:=[ [567.513,98.692,142.5], [0.707106781,0,0.707106781,0], [0,0,-
1,1], [9E+09,9E+09,9E+09,9E+09,9E+09,9E+09]];
CONST robtarget
B_B_1_10:=[ [565.814,130.406,142.5], [0.707106781,0,0.707106781,0], [0,0,-
1,1], [9E+09,9E+09,9E+09,9E+09,9E+09,9E+09]];
CONST robtarget
B_B_1_20:=[ [575.069,130.785,142.5], [0.707106781,0,0.707106781,0], [0,0,-
1,1], [9E+09,9E+09,9E+09,9E+09,9E+09,9E+09]];
CONST robtarget
B_B_1_30:=[ [578.408,129.495,142.5], [0.707106781,0,0.707106781,0], [0,0,-
1,1], [9E+09,9E+09,9E+09,9E+09,9E+09,9E+09]];
CONST robtarget
B_B_1_40:=[ [580.835,126.764,142.5], [0.707106781,0,0.707106781,0], [0,0,-
1,1], [9E+09,9E+09,9E+09,9E+09,9E+09,9E+09]];
CONST robtarget
B_B_1_50:=[ [581.594,123.578,142.5], [0.707106781,0,0.707106781,0], [0,0,-
1,1], [9E+09,9E+09,9E+09,9E+09,9E+09,9E+09]];
CONST robtarget
B_B_1_60:=[ [580.987,119.785,142.5], [0.707106781,0,0.707106781,0], [0,0,-
1,1], [9E+09,9E+09,9E+09,9E+09,9E+09,9E+09]];
CONST robtarget
B_B_1_70:=[ [578.787,117.281,142.5], [0.707106781,0,0.707106781,0], [0,0,-
1,1], [9E+09,9E+09,9E+09,9E+09,9E+09,9E+09]];
CONST robtarget
B_B_1_80:=[ [573.931,114.626,142.5], [0.707106781,0,0.707106781,0], [0,0,-
1,1], [9E+09,9E+09,9E+09,9E+09,9E+09,9E+09]];
CONST robtarget
B_B_1_90:=[ [570.366,114.398,142.5], [0.707106781,0,0.707106781,0], [0,0,-
1,1], [9E+09,9E+09,9E+09,9E+09,9E+09,9E+09]];
CONST robtarget
B_B_1_100:=[ [565.738,114.474,142.5], [0.707106781,0,0.707106781,0], [0,0,-
1,1], [9E+09,9E+09,9E+09,9E+09,9E+09,9E+09]];

```

```

CONST robtarget
B_B_2_10:=[ [565.435,113.943,142.5], [0.707106781,0,0.707106781,0], [0,0,-
1,1], [9E+09,9E+09,9E+09,9E+09,9E+09,9E+09] ];
CONST robtarget
B_B_2_20:=[ [574.69,114.474,142.5], [0.707106781,0,0.707106781,0], [0,0,-
1,1], [9E+09,9E+09,9E+09,9E+09,9E+09,9E+09] ];
CONST robtarget
B_B_2_30:=[ [579.697,112.274,142.5], [0.707106781,0,0.707106781,0], [0,0,-
1,1], [9E+09,9E+09,9E+09,9E+09,9E+09,9E+09] ];
CONST robtarget
B_B_2_40:=[ [582.201,109.846,142.5], [0.707106781,0,0.707106781,0], [0,0,-
1,1], [9E+09,9E+09,9E+09,9E+09,9E+09,9E+09] ];
CONST robtarget
B_B_2_50:=[ [583.263,105.143,142.5], [0.707106781,0,0.707106781,0], [0,0,-
1,1], [9E+09,9E+09,9E+09,9E+09,9E+09,9E+09] ];
CONST robtarget
B_B_2_60:=[ [582.049,101.198,142.5], [0.707106781,0,0.707106781,0], [0,0,-
1,1], [9E+09,9E+09,9E+09,9E+09,9E+09,9E+09] ];
CONST robtarget
B_B_2_70:=[ [579.09,98.163,142.5], [0.707106781,0,0.707106781,0], [0,0,-
1,1], [9E+09,9E+09,9E+09,9E+09,9E+09,9E+09] ];
CONST robtarget
B_B_2_80:=[ [574.387,97.177,142.5], [0.707106781,0,0.707106781,0], [0,0,-
1,1], [9E+09,9E+09,9E+09,9E+09,9E+09,9E+09] ];
CONST robtarget
B_B_2_90:=[ [570.214,97.025,142.5], [0.707106781,0,0.707106781,0], [0,0,-
1,1], [9E+09,9E+09,9E+09,9E+09,9E+09,9E+09] ];
CONST robtarget
B_B_2_100:=[ [567.483,97.101,142.5], [0.707106781,0,0.707106781,0], [0,0,-
1,1], [9E+09,9E+09,9E+09,9E+09,9E+09,9E+09] ];
CONST robtarget
B_B_2_110:=[ [565.814,97.177,142.5], [0.707106781,0,0.707106781,0], [0,0,-
1,1], [9E+09,9E+09,9E+09,9E+09,9E+09,9E+09] ];
CONST robtarget
B_IZLAZ:=[ [567.513,129.147,152.5], [0.707106781,0,0.707106781,0], [0,0,-
1,1], [9E+09,9E+09,9E+09,9E+09,9E+09,9E+09] ];
CONST robtarget
B_10_2:=[ [563.593,132.5,137.5], [0.707106781,0,0.707106781,0], [0,0,-
1,1], [9E+09,9E+09,9E+09,9E+09,9E+09,9E+09] ];
CONST robtarget
B_20_2:=[ [576.238,132.5,137.5], [0.707106781,0,0.707106781,0], [0,0,-
1,1], [9E+09,9E+09,9E+09,9E+09,9E+09,9E+09] ];
CONST robtarget
B_30_2:=[ [579.539,131.231,137.5], [0.707106781,0,0.707106781,0], [0,0,-
1,1], [9E+09,9E+09,9E+09,9E+09,9E+09,9E+09] ];
CONST robtarget
B_40_2:=[ [582.15,128.69,137.5], [0.707106781,0,0.707106781,0], [0,0,-
1,1], [9E+09,9E+09,9E+09,9E+09,9E+09,9E+09] ];
CONST robtarget
B_50_2:=[ [583.542,125.249,137.5], [0.707106781,0,0.707106781,0], [0,0,-
1,1], [9E+09,9E+09,9E+09,9E+09,9E+09,9E+09] ];
CONST robtarget
B_60_2:=[ [583.411,121.525,137.5], [0.707106781,0,0.707106781,0], [0,0,-
1,1], [9E+09,9E+09,9E+09,9E+09,9E+09,9E+09] ];
CONST robtarget
B_70_2:=[ [581.642,118.017,137.5], [0.707106781,0,0.707106781,0], [0,0,-
1,1], [9E+09,9E+09,9E+09,9E+09,9E+09,9E+09] ];
CONST robtarget
B_80_2:=[ [579.528,116.15,137.5], [0.707106781,0,0.707106781,0], [0,0,-
1,1], [9E+09,9E+09,9E+09,9E+09,9E+09,9E+09] ];

```

```

CONST robtarget
B_90_2:=[ [576.133,114.928,137.5], [0.707106781,0,0.707106781,0], [0,0,-1,1], [9E+09,9E+09,9E+09,9E+09,9E+09,9E+09] ];
CONST robtarget
B_100_2:=[ [579.463,114.269,137.5], [0.707106781,0,0.707106781,0], [0,0,-1,1], [9E+09,9E+09,9E+09,9E+09,9E+09,9E+09] ];
CONST robtarget
B_110_2:=[ [581.865,112.916,137.5], [0.707106781,0,0.707106781,0], [0,0,-1,1], [9E+09,9E+09,9E+09,9E+09,9E+09,9E+09] ];
CONST robtarget
B_120_2:=[ [584.072,110.536,137.5], [0.707106781,0,0.707106781,0], [0,0,-1,1], [9E+09,9E+09,9E+09,9E+09,9E+09,9E+09] ];
CONST robtarget
B_130_2:=[ [585.458,107.182,137.5], [0.707106781,0,0.707106781,0], [0,0,-1,1], [9E+09,9E+09,9E+09,9E+09,9E+09,9E+09] ];
CONST robtarget
B_140_2:=[ [585.537,103.67,137.5], [0.707106781,0,0.707106781,0], [0,0,-1,1], [9E+09,9E+09,9E+09,9E+09,9E+09,9E+09] ];
CONST robtarget
B_150_2:=[ [583.935,99.684,137.5], [0.707106781,0,0.707106781,0], [0,0,-1,1], [9E+09,9E+09,9E+09,9E+09,9E+09,9E+09] ];
CONST robtarget
B_160_2:=[ [581.876,97.515,137.5], [0.707106781,0,0.707106781,0], [0,0,-1,1], [9E+09,9E+09,9E+09,9E+09,9E+09,9E+09] ];
CONST robtarget
B_170_2:=[ [578.925,95.962,137.5], [0.707106781,0,0.707106781,0], [0,0,-1,1], [9E+09,9E+09,9E+09,9E+09,9E+09,9E+09] ];
CONST robtarget
B_180_2:=[ [577.248,95.58,137.5], [0.707106781,0,0.707106781,0], [0,0,-1,1], [9E+09,9E+09,9E+09,9E+09,9E+09,9E+09] ];
CONST robtarget
B_190_2:=[ [574.328,95.627,137.5], [0.707106781,0,0.707106781,0], [0,0,-1,1], [9E+09,9E+09,9E+09,9E+09,9E+09,9E+09] ];
CONST robtarget
B_200_2:=[ [572.122,95.5,137.5], [0.707106781,0,0.707106781,0], [0,0,-1,1], [9E+09,9E+09,9E+09,9E+09,9E+09,9E+09] ];
CONST robtarget
B_210_2:=[ [569.351,95.5,137.5], [0.707106781,0,0.707106781,0], [0,0,-1,1], [9E+09,9E+09,9E+09,9E+09,9E+09,9E+09] ];
CONST robtarget
B_220_2:=[ [567.058,95.5,137.5], [0.707106781,0,0.707106781,0], [0,0,-1,1], [9E+09,9E+09,9E+09,9E+09,9E+09,9E+09] ];
CONST robtarget
B_230_2:=[ [563.593,95.5,137.5], [0.707106781,0,0.707106781,0], [0,0,-1,1], [9E+09,9E+09,9E+09,9E+09,9E+09,9E+09] ];
CONST robtarget
B_B_1_10_2:=[ [565.814,130.406,137.5], [0.707106781,0,0.707106781,0], [0,0,-1,1], [9E+09,9E+09,9E+09,9E+09,9E+09,9E+09] ];
CONST robtarget
B_B_1_20_2:=[ [575.069,130.785,137.5], [0.707106781,0,0.707106781,0], [0,0,-1,1], [9E+09,9E+09,9E+09,9E+09,9E+09,9E+09] ];
CONST robtarget
B_B_1_30_2:=[ [578.408,129.495,137.5], [0.707106781,0,0.707106781,0], [0,0,-1,1], [9E+09,9E+09,9E+09,9E+09,9E+09,9E+09] ];
CONST robtarget
B_B_1_40_2:=[ [580.835,126.764,137.5], [0.707106781,0,0.707106781,0], [0,0,-1,1], [9E+09,9E+09,9E+09,9E+09,9E+09,9E+09] ];
CONST robtarget
B_B_1_50_2:=[ [581.594,123.578,137.5], [0.707106781,0,0.707106781,0], [0,0,-1,1], [9E+09,9E+09,9E+09,9E+09,9E+09,9E+09] ];

```

```

CONST robtarget
B_B_1_60_2:=[580.987,119.785,137.5],[0.707106781,0,0.707106781,0],[0,0,-
1,1],[9E+09,9E+09,9E+09,9E+09,9E+09,9E+09]];
CONST robtarget
B_B_1_70_2:=[578.787,117.281,137.5],[0.707106781,0,0.707106781,0],[0,0,-
1,1],[9E+09,9E+09,9E+09,9E+09,9E+09,9E+09]];
CONST robtarget
B_B_1_80_2:=[573.931,114.626,137.5],[0.707106781,0,0.707106781,0],[0,0,-
1,1],[9E+09,9E+09,9E+09,9E+09,9E+09,9E+09]];
CONST robtarget
B_B_1_90_2:=[570.366,114.398,137.5],[0.707106781,0,0.707106781,0],[0,0,-
1,1],[9E+09,9E+09,9E+09,9E+09,9E+09,9E+09]];
CONST robtarget
B_B_1_100_2:=[565.738,114.474,137.5],[0.707106781,0,0.707106781,0],[0,0,-
1,1],[9E+09,9E+09,9E+09,9E+09,9E+09,9E+09]];
CONST robtarget
B_B_2_10_2:=[565.435,113.943,137.5],[0.707106781,0,0.707106781,0],[0,0,-
1,1],[9E+09,9E+09,9E+09,9E+09,9E+09,9E+09]];
CONST robtarget
B_B_2_20_2:=[574.69,114.474,137.5],[0.707106781,0,0.707106781,0],[0,0,-
1,1],[9E+09,9E+09,9E+09,9E+09,9E+09,9E+09]];
CONST robtarget
B_B_2_30_2:=[579.697,112.274,137.5],[0.707106781,0,0.707106781,0],[0,0,-
1,1],[9E+09,9E+09,9E+09,9E+09,9E+09,9E+09]];
CONST robtarget
B_B_2_40_2:=[582.201,109.846,137.5],[0.707106781,0,0.707106781,0],[0,0,-
1,1],[9E+09,9E+09,9E+09,9E+09,9E+09,9E+09]];
CONST robtarget
B_B_2_50_2:=[583.263,105.143,137.5],[0.707106781,0,0.707106781,0],[0,0,-
1,1],[9E+09,9E+09,9E+09,9E+09,9E+09,9E+09]];
CONST robtarget
B_B_2_60_2:=[582.049,101.198,137.5],[0.707106781,0,0.707106781,0],[0,0,-
1,1],[9E+09,9E+09,9E+09,9E+09,9E+09,9E+09]];
CONST robtarget
B_B_2_70_2:=[579.09,98.163,137.5],[0.707106781,0,0.707106781,0],[0,0,-
1,1],[9E+09,9E+09,9E+09,9E+09,9E+09,9E+09]];
CONST robtarget
B_B_2_80_2:=[574.387,97.177,137.5],[0.707106781,0,0.707106781,0],[0,0,-
1,1],[9E+09,9E+09,9E+09,9E+09,9E+09,9E+09]];
CONST robtarget
B_B_2_90_2:=[570.214,97.025,137.5],[0.707106781,0,0.707106781,0],[0,0,-
1,1],[9E+09,9E+09,9E+09,9E+09,9E+09,9E+09]];
CONST robtarget
B_B_2_100_2:=[567.483,97.101,137.5],[0.707106781,0,0.707106781,0],[0,0,-
1,1],[9E+09,9E+09,9E+09,9E+09,9E+09,9E+09]];
CONST robtarget
B_B_2_110_2:=[565.814,97.177,137.5],[0.707106781,0,0.707106781,0],[0,0,-
1,1],[9E+09,9E+09,9E+09,9E+09,9E+09,9E+09]];
CONST robtarget
PICKING_VUB1:=[415.102,0,210],[0,0,1,0],[0,0,0,0],[9E+09,9E+09,9E+09,9E+09,9
E+09,9E+09]];
CONST robtarget
PICKING_VUB2:=[415.102,0,10],[0,0,1,0],[0,0,0,0],[9E+09,9E+09,9E+09,9E+09,9E
+09,9E+09]];
CONST robtarget
B_240_2:=[567.513,129.147,137.5],[0.707106781,0,0.707106781,0],[0,0,-
1,1],[9E+09,9E+09,9E+09,9E+09,9E+09,9E+09]];
CONST robtarget
B_250_2:=[573.46,129.147,137.5],[0.707106781,0,0.707106781,0],[0,0,-
1,1],[9E+09,9E+09,9E+09,9E+09,9E+09,9E+09]];

```

```

CONST robtarget
B_260_2:=[ [577.023,128.133,137.5], [0.707106781,0,0.707106781,0], [0,0,-
1,1], [9E+09,9E+09,9E+09,9E+09,9E+09,9E+09]];
CONST robtarget
B_270_2:=[ [578.848,126.474,137.5], [0.707106781,0,0.707106781,0], [0,0,-
1,1], [9E+09,9E+09,9E+09,9E+09,9E+09,9E+09]];
CONST robtarget
B_280_2:=[ [580.14,123.465,137.5], [0.707106781,0,0.707106781,0], [0,0,-
1,1], [9E+09,9E+09,9E+09,9E+09,9E+09,9E+09]];
CONST robtarget
B_290_2:=[ [579.855,120.162,137.5], [0.707106781,0,0.707106781,0], [0,0,-
1,1], [9E+09,9E+09,9E+09,9E+09,9E+09,9E+09]];
CONST robtarget
B_300_2:=[ [578.564,117.933,137.5], [0.707106781,0,0.707106781,0], [0,0,-
1,1], [9E+09,9E+09,9E+09,9E+09,9E+09,9E+09]];
CONST robtarget
B_310_2:=[ [575.984,116.098,137.5], [0.707106781,0,0.707106781,0], [0,0,-
1,1], [9E+09,9E+09,9E+09,9E+09,9E+09,9E+09]];
CONST robtarget
B_320_2:=[ [573.842,115.62,137.5], [0.707106781,0,0.707106781,0], [0,0,-
1,1], [9E+09,9E+09,9E+09,9E+09,9E+09,9E+09]];
CONST robtarget
B_330_2:=[ [571.485,115.379,137.5], [0.707106781,0,0.707106781,0], [0,0,-
1,1], [9E+09,9E+09,9E+09,9E+09,9E+09,9E+09]];
CONST robtarget
B_340_2:=[ [569.053,115.609,137.5], [0.707106781,0,0.707106781,0], [0,0,-
1,1], [9E+09,9E+09,9E+09,9E+09,9E+09,9E+09]];
CONST robtarget
B_350_2:=[ [567.513,115.609,137.5], [0.707106781,0,0.707106781,0], [0,0,-
1,1], [9E+09,9E+09,9E+09,9E+09,9E+09,9E+09]];
CONST robtarget
B_360_2:=[ [567.513,112.809,137.5], [0.707106781,0,0.707106781,0], [0,0,-
1,1], [9E+09,9E+09,9E+09,9E+09,9E+09,9E+09]];
CONST robtarget
B_370_2:=[ [573.366,112.809,137.5], [0.707106781,0,0.707106781,0], [0,0,-
1,1], [9E+09,9E+09,9E+09,9E+09,9E+09,9E+09]];
CONST robtarget
B_380_2:=[ [577.453,112.068,137.5], [0.707106781,0,0.707106781,0], [0,0,-
1,1], [9E+09,9E+09,9E+09,9E+09,9E+09,9E+09]];
CONST robtarget
B_390_2:=[ [580.199,109.555,137.5], [0.707106781,0,0.707106781,0], [0,0,-
1,1], [9E+09,9E+09,9E+09,9E+09,9E+09,9E+09]];
CONST robtarget
B_400_2:=[ [581.299,106.007,137.5], [0.707106781,0,0.707106781,0], [0,0,-
1,1], [9E+09,9E+09,9E+09,9E+09,9E+09,9E+09]];
CONST robtarget
B_410_2:=[ [580.526,102.518,137.5], [0.707106781,0,0.707106781,0], [0,0,-
1,1], [9E+09,9E+09,9E+09,9E+09,9E+09,9E+09]];
CONST robtarget
B_420_2:=[ [578.583,100.158,137.5], [0.707106781,0,0.707106781,0], [0,0,-
1,1], [9E+09,9E+09,9E+09,9E+09,9E+09,9E+09]];
CONST robtarget
B_430_2:=[ [576.639,99.076,137.5], [0.707106781,0,0.707106781,0], [0,0,-
1,1], [9E+09,9E+09,9E+09,9E+09,9E+09,9E+09]];
CONST robtarget
B_440_2:=[ [574.052,98.645,137.5], [0.707106781,0,0.707106781,0], [0,0,-
1,1], [9E+09,9E+09,9E+09,9E+09,9E+09,9E+09]];
CONST robtarget
B_450_2:=[ [571.296,98.692,137.5], [0.707106781,0,0.707106781,0], [0,0,-
1,1], [9E+09,9E+09,9E+09,9E+09,9E+09,9E+09]];

```

```

CONST robtarget
B_460_2:=[[567.513,98.692,137.5],[0.707106781,0,0.707106781,0],[0,0,-
1,1],[9E+09,9E+09,9E+09,9E+09,9E+09,9E+09]];
CONST robtarget DROPPING_VUB1:=[[415.102,-
200,210],[0,0,1,0],[0,0,0,0],[9E+09,9E+09,9E+09,9E+09,9E+09,9E+09]];
CONST robtarget DROPPING_VUB2:=[[415.102,-
200,10],[0,0,1,0],[0,0,0,0],[9E+09,9E+09,9E+09,9E+09,9E+09,9E+09]];
!*****
!
! Module:  Module1
!
! Description:
!   <Insert description here>
!
! Author:  marko
!
! Version: 1.0
!
!*****

!*****
!
! Procedure main
!
!   This is the entry point of your program
!
!*****
PROC main()
  Reset HVAT;
  START;
  V;
  U;
  B;
  PICKING;
  DROPPING;
ENDPROC
PROC V()
  MoveJ V_ULAZ,v10,fine,SCHUNK_PROXXON_DRZAC\Wobj:=wobj0;
  MoveL V_10,v10,fine,SCHUNK_PROXXON_DRZAC\Wobj:=wobj0;
  MoveL V_20,v10,fine,SCHUNK_PROXXON_DRZAC\Wobj:=wobj0;
  MoveL V_30,v10,fine,SCHUNK_PROXXON_DRZAC\Wobj:=wobj0;
  MoveL V_40,v10,fine,SCHUNK_PROXXON_DRZAC\Wobj:=wobj0;
  MoveL V_50,v10,fine,SCHUNK_PROXXON_DRZAC\Wobj:=wobj0;
  MoveL V_60,v10,fine,SCHUNK_PROXXON_DRZAC\Wobj:=wobj0;
  MoveL V_70,v10,fine,SCHUNK_PROXXON_DRZAC\Wobj:=wobj0;
  MoveL V_10,v10,fine,SCHUNK_PROXXON_DRZAC\Wobj:=wobj0;
  MoveL V_V_10,v10,fine,SCHUNK_PROXXON_DRZAC\Wobj:=wobj0;
  MoveL V_V_20,v10,fine,SCHUNK_PROXXON_DRZAC\Wobj:=wobj0;
  MoveL V_V_30,v10,fine,SCHUNK_PROXXON_DRZAC\Wobj:=wobj0;
  MoveL V_V_40,v10,fine,SCHUNK_PROXXON_DRZAC\Wobj:=wobj0;
  MoveL V_IZLAZ,v10,fine,SCHUNK_PROXXON_DRZAC\Wobj:=wobj0;
  MoveL V_ULAZ,v10,fine,SCHUNK_PROXXON_DRZAC\Wobj:=wobj0;
  MoveL V_10_2,v10,fine,SCHUNK_PROXXON_DRZAC\Wobj:=wobj0;
  MoveL V_20_2,v10,fine,SCHUNK_PROXXON_DRZAC\Wobj:=wobj0;
  MoveL V_30_2,v10,fine,SCHUNK_PROXXON_DRZAC\Wobj:=wobj0;
  MoveL V_40_2,v10,fine,SCHUNK_PROXXON_DRZAC\Wobj:=wobj0;
  MoveL V_50_2,v10,fine,SCHUNK_PROXXON_DRZAC\Wobj:=wobj0;
  MoveL V_60_2,v10,fine,SCHUNK_PROXXON_DRZAC\Wobj:=wobj0;
  MoveL V_70_2,v10,fine,SCHUNK_PROXXON_DRZAC\Wobj:=wobj0;
  MoveL V_10_2,v10,fine,SCHUNK_PROXXON_DRZAC\Wobj:=wobj0;

```



```

ENDPROC
PROC START ()
    MoveJ HOME_SCHUNK, v300, fine, SCHUNK_PROXXON_DRZAC\Wobj:=wobj0;
    WaitTime\InPos, 1;
    Reset HVAT;
    WaitTime\InPos, 1;
    MoveJ
VUB_1T_HOME_OFFSET, v300, fine, SCHUNK_PROXXON_DRZAC\Wobj:=wobj0;
    WaitTime\InPos, 2;
ENDPROC
PROC PICKING ()
    MoveJ HOME_SCHUNK, v300, fine, SCHUNK_PROXXON_DRZAC\Wobj:=wobj0;
    MoveJ PICKING_VUB1, v50, fine, SCHUNK_PROXXON_DRZAC\Wobj:=wobj0;
        WaitTime\InPos, 1;
        MoveL PICKING_VUB2, v50, fine, SCHUNK_PROXXON_DRZAC\Wobj:=wobj0;
    WaitTime\InPos, 0.5;
    Set HVAT;
    WaitTime\InPos, 0.5;
    MoveL PICKING_VUB1, v50, fine, SCHUNK_PROXXON_DRZAC\Wobj:=wobj0;
ENDPROC
PROC DROPPING ()
    MoveL DROPPING_VUB1, v50, fine, SCHUNK_PROXXON_DRZAC\Wobj:=wobj0;
    WaitTime\InPos, 1;
    MoveL DROPPING_VUB2, v50, fine, SCHUNK_PROXXON_DRZAC\Wobj:=wobj0;
    WaitTime\InPos, 0.5;
    Reset HVAT;
    WaitTime\InPos, 0.5;
    MoveL DROPPING_VUB1, v50, fine, SCHUNK_PROXXON_DRZAC\Wobj:=wobj0;
    MoveJ HOME_SCHUNK, v300, fine, SCHUNK_PROXXON_DRZAC\Wobj:=wobj0;
ENDPROC
ENDMODULE

```

IZJAVA O AUTORSTVU ZAVRŠNOG RADA

Pod punom odgovornošću izjavljujem da sam ovaj rad izradio/la samostalno, poštujući načela akademske čestitosti, pravila struke te pravila i norme standardnog hrvatskog jezika. Rad je moje autorsko djelo i svi su preuzeti citati i parafraze u njemu primjereno označeni.

Mjesto i datum	Ime i prezime studenta/ice	Potpis studenta/ice
U Bjelovaru, <u>26.10.2021.</u>	MARCO MUDRI	<i>Marco Mudri</i>

Prema Odluci Veleučilišta u Bjelovaru, a u skladu sa Zakonom o znanstvenoj djelatnosti i visokom obrazovanju, elektroničke inačice završnih radova studenata Veleučilišta u Bjelovaru bit će pohranjene i javno dostupne u internetskoj bazi Nacionalne i sveučilišne knjižnice u Zagrebu. Ukoliko ste suglasni da tekst Vašeg završnog rada u cijelosti bude javno objavljen, molimo Vas da to potvrdite potpisom.

Suglasnost za objavljivanje elektroničke inačice završnog rada u javno dostupnom nacionalnom repozitoriju

MARCO MUORI

ime i prezime studenta/ice

Dajem suglasnost da se radi promicanja otvorenog i slobodnog pristupa znanju i informacijama cjeloviti tekst mojeg završnog rada pohrani u repozitorij Nacionalne i sveučilišne knjižnice u Zagrebu i time učini javno dostupnim.

Svojim potpisom potvrđujem istovjetnost tiskane i elektroničke inačice završnog rada.

U Bjelovaru, 26.10.2021.

Marko Muori
potpis studenta/ice